



Donut Fryers

Models CE-CN-1700-F, 3300-F

Items 44522, 48522

Instruction Manual



Revised - 12/04/2025



Toll Free: 1-800-465-0234
Fax: 905-607-0234
Email: service@omcan.com
www.omcan.com



Table of Contents

Model CE-CN-1700-F / Model CE-CN-3300-F

Section	Page
General Information -----	3 - 4
Safety and Warranty -----	4 - 6
Technical Specifications -----	6
Installation and Operation -----	7
Maintenance -----	8
Troubleshooting -----	8
Parts Breakdown -----	9 - 11
Electrical Schematics -----	12 - 13
Notes -----	14
Warranty Registration -----	15



General Information

Omcan Manufacturing and Distributing Company Inc., Food Machinery of America, Inc. dba Omcan and Omcan Inc. are not responsible for any harm or injury caused due to any person's improper or negligent use of this equipment. The product shall only be operated by someone over the age of 18, of sound mind, and not under the influence of any drugs or alcohol, who has been trained in the correct operation of this machine, and is wearing authorized, proper safety clothing. Any modification to the machine voids any warranty, and may cause harm to individuals using the machine or in the vicinity of the machine while in operation.

CHECK PACKAGE UPON ARRIVAL

Upon receipt of an Omcan shipment please inspect for external damage. If no damage is evident on the external packaging, open carton to ensure all ordered items are within the box, and there is no concealed damage to the machine. If the package has suffered rough handling, bumps or damage (visible or concealed), please note it on the bill of lading before accepting the delivery and contact Omcan within 24 hours, so we may initiate a claim with the carrier. A detailed report on the extent of the damage caused to the machine must be filled out within three days, from the delivery date shown in the shipping documents. Omcan has no recourse for damaged products that were shipped collect or third party.

Before operating any equipment, always read and familiarize yourself with all operation and safety instructions.

Omcan would like to thank you for purchasing this machine. It's of the utmost importance to save these instructions for future reference. Also save the original box and packaging for shipping the equipment if servicing or returning of the machine is required.

Omcan Fabrication et distribution Compagnie Limitée et Food Machinery d'Amérique, dba Omcan et Omcan Inc. ne sont pas responsables de tout dommage ou blessure causé du fait que toute personne ait utilisé cet équipement de façon irrégulière. Le produit ne doit être exploité que par quelqu'un de plus de 18 ans, saine d'esprit, et pas sous l'influence d'une drogue ou d'alcool, qui a été formé pour utiliser cette machine correctement, et est vêtu de vêtements de sécurité appropriés. Toute modification de la machine annule toute garantie, et peut causer un préjudice à des personnes utilisant la machine ou des personnes à proximité de la machine pendant son fonctionnement.

VÉRIFIEZ LE COLIS DÈS RÉCEPTION

Dès réception d'une expédition d'Omcan veuillez inspecter pour dommages externes. Si aucun dommage n'est visible sur l'emballage externe, ouvrez le carton afin de s'assurer que tous les éléments commandés sont dans la boîte, et il n'y a aucun dommage dissimulé à la machine. Si le colis n'a subi aucune mauvaises manipulations, de bosses ou de dommages (visible ou cachée), notez-le sur le bond de livraison avant d'accepter la livraison et contactez Omcan dans les 24 heures qui suivent, pour que nous puissions engager une réclamation auprès du transporteur. Un rapport détaillé sur l'étendue des dommages causés à la machine doit être rempli dans un délai de trois jours, à compter de la date de livraison indiquée dans les documents d'expédition. Omcan n'a aucun droit de recours pour les produits endommagés qui ont été expédiés ou cueillis par un tiers transporteur.

Avant d'utiliser n'importe quel équipement, toujours lire et vous familiariser avec toutes les opérations et les

General Information

consignes de sécurité.

Omcan voudrais vous remercier d'avoir choisi cette machine. Il est primordial de conserver ces instructions pour une référence ultérieure. Également conservez la boîte originale et l'emballage pour l'expédition de l'équipement si l'entretien ou le retour de la machine est nécessaire.

Omcan Empresa De Fabricacion Y Distribucion Inc. Y Maquinaria De Alimentos De America, Inc. dba Omcan y Omcan Inc. no son responsables de ningun daño o perjuicio causado por cualquier persona inadecuada o el uso descuidado de este equipo. El producto solo podra ser operado por una persona mayor de 18 años, en su sano juicio y no bajo alguna influencia de droga o alcohol, y que este ha sido entrenado en el correcto funcionamiento de esta máquina, y ésta usando ropa apropiada y autorizada. Cualquier modificación a la máquina anula la garantía y puede causar daños a las personas usando la máquina mientras esta en el funcionamiento.

REVISE EL PAQUETE A SU LLEGADA

Tras la recepcion de un envio Omcan favor inspeccionar daños externos. Si no hay daños evidentes en el empaque exterior, Habra el carton para asegurarse que todos los articulos solicitados estén dentro de la caja y no encuentre daños ocultos en la máquina. Si el paquete ha sufrido un manejo de poco cuidado, golpes o daños (visible o oculto) por favor anote en la factura antes de aceptar la entrega y contacte Omcan dentro de las 24 horas, de modo que podamos iniciar una reclamación con la compañía. Un informe detallado sobre los daños causados a la máquina debe ser llenado en el plazo de tres días, desde la fecha de entrega que se muestra en los documentos de envío. Omcan no tiene ningun recurso por productos dañados que se enviaron a recoger por terceros.

Antes de utilizar cualquier equipo, siempre lea y familiarizarse con todas las instrucciones de funcionamiento y seguridad.

Omcan le gustaría darle las gracias por la compra de esta máquina. Es de la mayor importancia para salvar estas instrucciones para futuras consultas. Además, guarda la caja original y el embalaje para el envío del equipo si servicio técnico o devolución de la máquina que se requiere.

Safety and Warranty

WARNING!

ANY REFITTING OR WRONG INSTALLATION, ADJUSTMENT AND MAINTENANCE CAN CAUSE PROPERTY DAMAGE AND HARM. PLEASE CONTACT OMCAN IF YOU NEED TO ADJUST OR MAINTAIN IT AND ONLY AUTHORIZED PERSONS MAY MAKE THE ADJUSTMENTS.

WARNING!

DO NOT PUT FLAMMABLE LIQUID, GAS OR OTHER OBJECTS AROUND THE PRODUCT FOR YOUR SAFETY.

Safety and Warranty

WARNING!

THE PRODUCT IS NOT SUITABLE FOR PEOPLE WHO HAVE NOT BEEN TRAINED IN IT'S USE, OR PEOPLE WHO ARE INEXPERIENCE (INCLUDING CHILDREN).

NOTES FOR INSTALLATION

1. The supplied voltage for this equipment must be coordinated with the voltage in nameplate.
2. User should install a suitable power switch and breaker switch near the fryer.
3. At the back of the equipment is the earth bolt. Please connect the earth wire in compliance with the safety regulations reliably with copper cable of no less that 1.5mm².
4. The environment temperature should not be more than 300°C/572°F in the event of hot oil splashing and causing the fire.
5. The installation of this equipment must be done by professionals.
6. Using old oil will be easy to cause over boiling, and if the food too wet or too much, also the same problem will happen.

WARNING!

If the oil level is less than the "MIN" level marked on the tank, there will be a risk of catching fire.

NOTICE

- This equipment must be operated by trained cooks or professionals.
- Do not refit it! Refitment of this product will cause serious injury.
- Do not clean the product with a water jet or soak the electric box into water while cleaning. Water can conduct electricity so the product may cause electric-shock accident by electric leakage.
- High temperatures can and will scald. When the unit is in use and before or after being used, do not touch any of the following directly because of it's high temperature; body of trunk and chamber of top trunk.
- Do not use another power supply with different voltage. Do not use a main switch that is not coordinated with safety regulations.
- When there is thunder and lighting in the area, the user should shut off the main switch to avoid appliance being damaged by a power surge.
- Do not use hard and sharp objects to clean the surface of oven body and the surface of oil pot.
- After using, please shut off the main switch.
- The installation and maintenance of electric circuits must be done by professionals.
- If the power cord is damaged, to prevent a hazard, the user should contact Omcan to request a replacement.

WARNING!

- Daily check of the product is needed. It can prevent the accidents.
- If a problem is found with the electric circuit or the temperature rising is abnormal, please stop using the equipment immediately. And inform the professional technician to check and maintain as soon as possible.

Note: all fryer units are sprayed with anti-rust oil before shipment to prevent rusting during storage and transportation, which may result in a small amount of oil accumulating at the bottom of the tank.

RESIDENTIAL USERS: vendor assumes no liability for parts or labor coverage for component failure or other

Safety and Warranty

damages resulting from installation in non-commercial or residential applications. The right is reserved to deny shipment for residential usage; if this occurs, you will be notified as soon as possible.

1 YEAR PART AND LABOUR BENCH WARRANTY

Within the warranty period, contact Omcan Inc. at 1-800-465-0234 to schedule a drop off to either an Omcan authorized service depot in the area, or to an Omcan Service warehouse to repair the equipment.

Unauthorized maintenance will void the warranty. Warranty covers electrical and part failures, not improper use.

Please see <https://omcan.com/disclaimer> for complete info.

WARNING:

The packaging components (cardboard, polyethylene, and others) are classified as normal solid urban waste and can therefore be disposed of without difficulty.

In any case, for suitable recycling, we suggest disposing of the products separately (differentiated waste) according to the current norms.

DO NOT DISCARD ANY PACKAGING MATERIALS IN THE ENVIRONMENT!

Technical Specifications

Model	CE-CN-1700-F	CE-CN-3300-F
Item Number	44522	48522
Power	1.7 kW	3.3 - 4.4 kW
Volume of Oil	25 lbs. / 11.3 kgs.	
Adjustable Temperature	93.3 - 187.8°C / 200 - 370°F	
Electrical	110-120V / 60Hz / 1	208-240V / 60Hz / 1
Current	14.5A	15.9 - 18.3A
Cooking Area	17.7" x 17.7" x 6" / 450 x 450 x 152mm	
Screen Capacity	1	
Screen Dimensions	15" x 14" / 379 x 355mm	
Net Dimensions (DWH)	18" x 24" x 14" / 460 x 616 x 355mm	
Net Weight	35.3 lbs. / 16 kgs.	
Packaging Weight	39.7 lbs. / 18 kgs.	

Installation and Operation

1. Ensure the unit is plugged in correctly, and make sure the supplied voltage is the same as the voltage on the rating plate.
2. Turn over the tank cover, and place it securely beside the fryer.
3. There is an oil level mark in the internal tank, when using the fryer the quantity of oil in tank should be kept in certain level. "MAX" shows the maximum volume of oil, "MIN" shows the minimum volume of oil. When using, the user can adjust the volume of oil between those points if needed.
4. - Plug in the machine, the green indicator will turn on. The machine is powered and ready to be used.
- Rotate the temperature controller clockwise to the desired temperature. At this point, the yellow indicator will turn on and the green indicator will turn off. It shows that the unit is heating the oil in the tank.
5. - When the temperature of oil rises to the desired temperature, the temperature controller will cut off power automatically. At the same time, the yellow indicator will turn off and heater will turn off.
- When temperature of the oil gets too low, the temperature controller will automatically turn on again. The yellow indicator will turn on, and the heater will begin raising the oils temperature again.
- This process repeats until the unit is switched off.
6. The enclosed frying baskets are for frying donuts. Using one basket at a time, soak the basket in the oil when frying. After the frying is finished, lift the basket and place it on the tank cover to filter the excess oil. The user can continue to fry the food by using the other basket at this time.
7. After work is completed, please rotate the temperature controller counter-clockwise to the off and cut off the power for safety.
8. - Please pour the old oil out of the tank when the temperature of the oil lowers room temperature.
- First, cut off the power, then take the partition board for the oil out of tank, and then take the electric box out of the back notch in bottom box. The electric heating tube and electric box are separated from the tank, then take out the oil tank to clean.
9. In order to make sure the stove is safe and durable. The user should clean the oil tank and the electric heating tube in order to maintain consistent and hygienic quality when frying.
10. The partition board of the oil tank is designed for protecting the electric heating tube. Put the partition board into the oil tank when frying food.
11. - There is a temperature limiter in the electric box. When the oil temperature gets too hot, the temperature limiter will automatically turn the unit off.
- There is "reset button for over heating" on the back side of electric box. When the temperature limiter turns on, the reset button must be pressed before operation can resume.

TRANSPORTATION AND STORAGE

During transportation, the machine should be carefully handled. The packaged machine should not be stored outdoors. It should be put in a well ventilated indoor location without any corrosive gases in the same space. It should not be placed upside down.

Maintenance

- Cut off the power supply before cleaning in case of accident.
- Do not use a wet towel with a non-corrosive cleanser to clean the module plate, the surface of the

Maintenance

equipment and power cord. Do not was directly with water.

- If the unit is not in use at any time, please turn off temperature controller and main switch.
- Please store the equipment in a ventilated storehouse without corrosive gas after cleaning when stopping its work for a long time.

Troubleshooting

Problem	Possible Cause	Solution
The machine is plugged in, but the indicator does not turn on.	Plug is not inserted well.	Plug the unit in correctly.
	Micro-switch is not making contact.	Ensure the micro-switch is making contact.
The heating indicator is not on and the temperature is not rising.	Connection of the electric heating tube is loose.	Firmly connect the two sides of the electric heating tube and screw.
		Replace the electric heating tube.
The power indicator is on but the set temperature is not rising.	The temperature controller is burnt out.	Replace the temperature controller.
The temperature controller is normal but the indicator is not on.	The indicator is burnt out.	Replace the indicator.
The heater stops working after a circuit break.	The temperature limiter was activated.	Press the reset "over heating protecting button".
The temperature gets too hot.	The temperature limiter is faulty.	Replace the temperature limiter.

The aforementioned problems are just for reference. If any additional problems occur, please stop using the unit, and contact an Omcan technician at 1-800-465-0234.

NOTE: if the power cord damaged, please replace it with soft oil-proof cable jacket (GB/T 5013.1 (IEC 60245, IDT) Mid No. 57) or the power cord from the manufacture or service center. This must be done by a certified Omcan technician.

Parts Breakdown

Model CE-CN-1700-F 44522

Model CE-CN-3300-F 48522

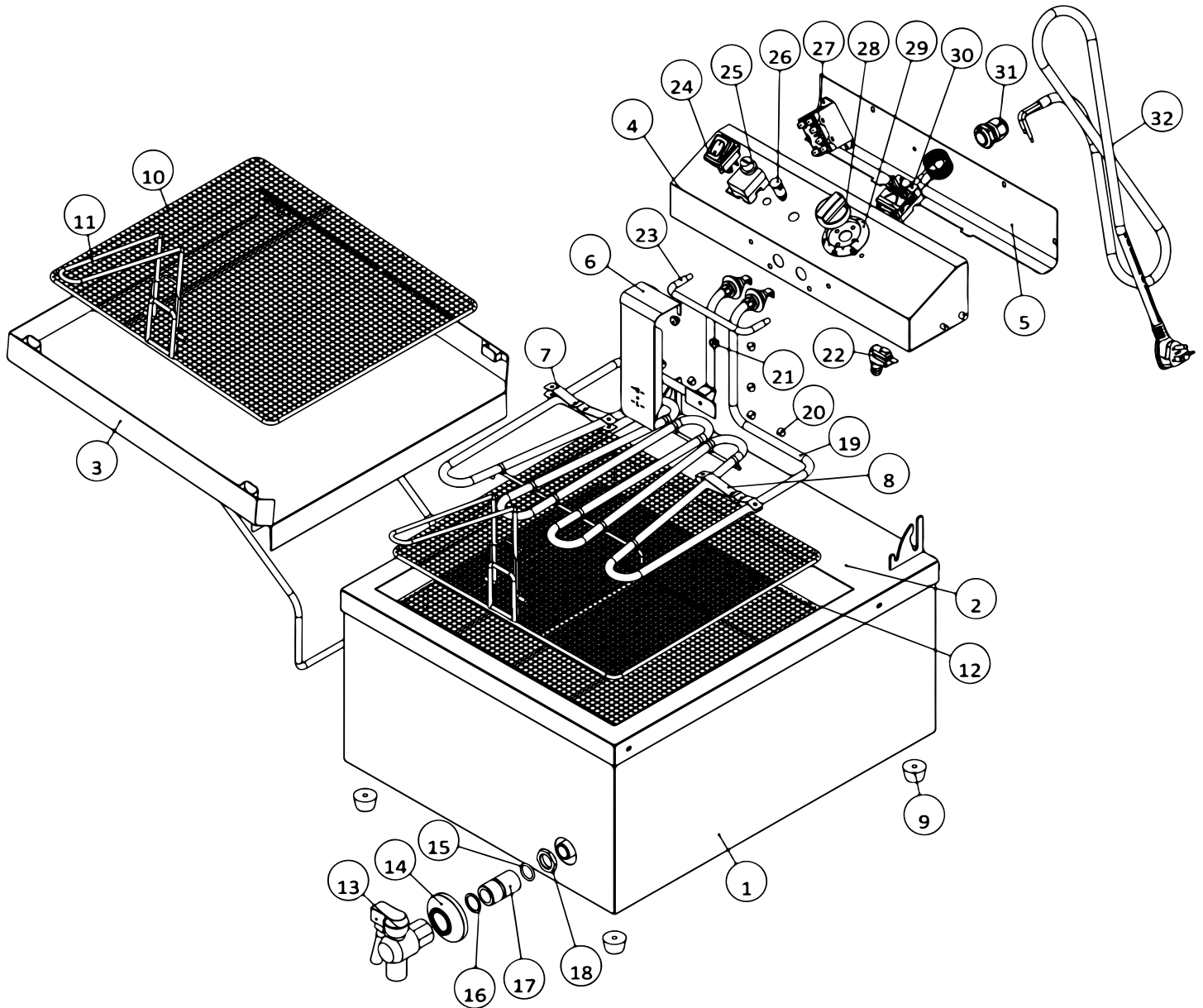

Parts Breakdown

Model CE-CN-1700-F 44522

Item No.	Description	Position	Item No.	Description	Position	Item No.	Description	Position
AQ391	Body Assembly for 44522	1	AE193	Drainage Valve for 44522	13	AQ403	Power Switch SR-13 250V/20A for 44522	24
AQ392	Tank Assembly for 44522	2	AE194	Decoration Ring for Drainage Valve for 44522	14	AN150	Hi Limit Switch (Reset) for 44522	25
AE171	Cover for Oil Pan for 44522	3	AQ398	Rubber Gasket for 44522	15	AQ404	Power Indicator (Green) 110V for 44522	26
AQ393	Rear Cover Assembly for 44522	4	AQ399	Seal Ring for Drain Valve for 44522	16	AQ405	Heating Indicator (Yellow) 110V for 44522	27
AQ394	Rear Cover of the Electrical Box for 44522	5	AE206	Joint of Drainage Valve for 44522	17	AE162	41 Knob for Thermostat for 44522	28
AQ395	Heating Element Cover Plate for 44522	6	AE198	G12 Hex Nut for 44522	18	AE161	Bezel for Thermostat Knob for 44522	29
AQ396	Hi-Limit Probe Mounting Clamp for 44522	7, 8	AQ400	Heating Element 120V/1.74kW for 44522	19	AE163	Ego Thermostat 200C for 44522	30
AE205	Rubber Foot for 44522	9	AQ401	Sensor Clamp for 44522	20	AO154	Power Cord Grip for 44522	31
AE190	Frying Basket 379x355mm for 44522	10	AQ402	Sensor Sheath for 44522	21	AQ406	Power Cord for 44522	32
AQ397	Basket Handle for 44522	11	AO166	Micro Switch on Control Panel for 44522	22			
AE189	Separating Net 389x365x35mm for 44522	12	AE192	Supporting Rod for Basket for 44522	23			

Parts Breakdown

Model CE-CN-3300-F 48522

Item No.	Description	Position	Item No.	Description	Position	Item No.	Description	Position
AQ391	Body Assembly for 48522	1	AE193	Drainage Valve for 48522	13	AQ403	Power Switch SR-13 250V/20A for 48522	24
AQ392	Tank Assembly for 48522	2	AE194	Decoration Ring for Drainage Valve for 48522	14	AN150	Hi Limit Switch (Reset) for 48522	25
AE171	Cover for Oil Pan for 48522	3	AQ398	Rubber Gasket for 48522	15	AR697	Heating Indicator (Yellow) 230V for 48522	26
AQ393	Rear Cover Assembly for 48522	4	AQ399	Seal Ring for Drain Valve for 48522	16	AR698	Relay for 48522	27
AQ394	Rear Cover of the Electrical Box for 48522	5	AE206	Joint of Drainage Valve for 48522	17	AE162	41 Knob for Thermostat for 48522	28
AQ395	Heating Element Cover Plate for 48522	6	AE198	G12 Hex Nut for 48522	18	AE161	Bezel for Thermostat Knob for 48522	29
AQ396	Hi-Limit Probe Mounting Clamp for 48522	7, 8	AR696	Heating Element 240V/4.4kW SS304 for 48522	19	AE163	EGO Thermostat 200C for 48522	30
AE205	Foot for 48522	9	AQ401	Sensor Clamp for 48522	20	AO154	Power Cord Grip for 48522	31
AE190	Frying Basket 379x355mm for 48522	10	AQ402	Sensor Sheath for 48522	21	AR699	Power Cord XN620P-A 250V/20A SJTO T105 12#AW for 48522	32
AQ397	Basket Handle for 48522	11	AO166	Micro Switch On Control Panel for 48522	22			
AE189	Separating Net 389x365x35mm for 48522	12	AE192	Supporting Rod for Basket for 48522	23			

Electrical Schematics

Model CE-CN-1700-F 44522

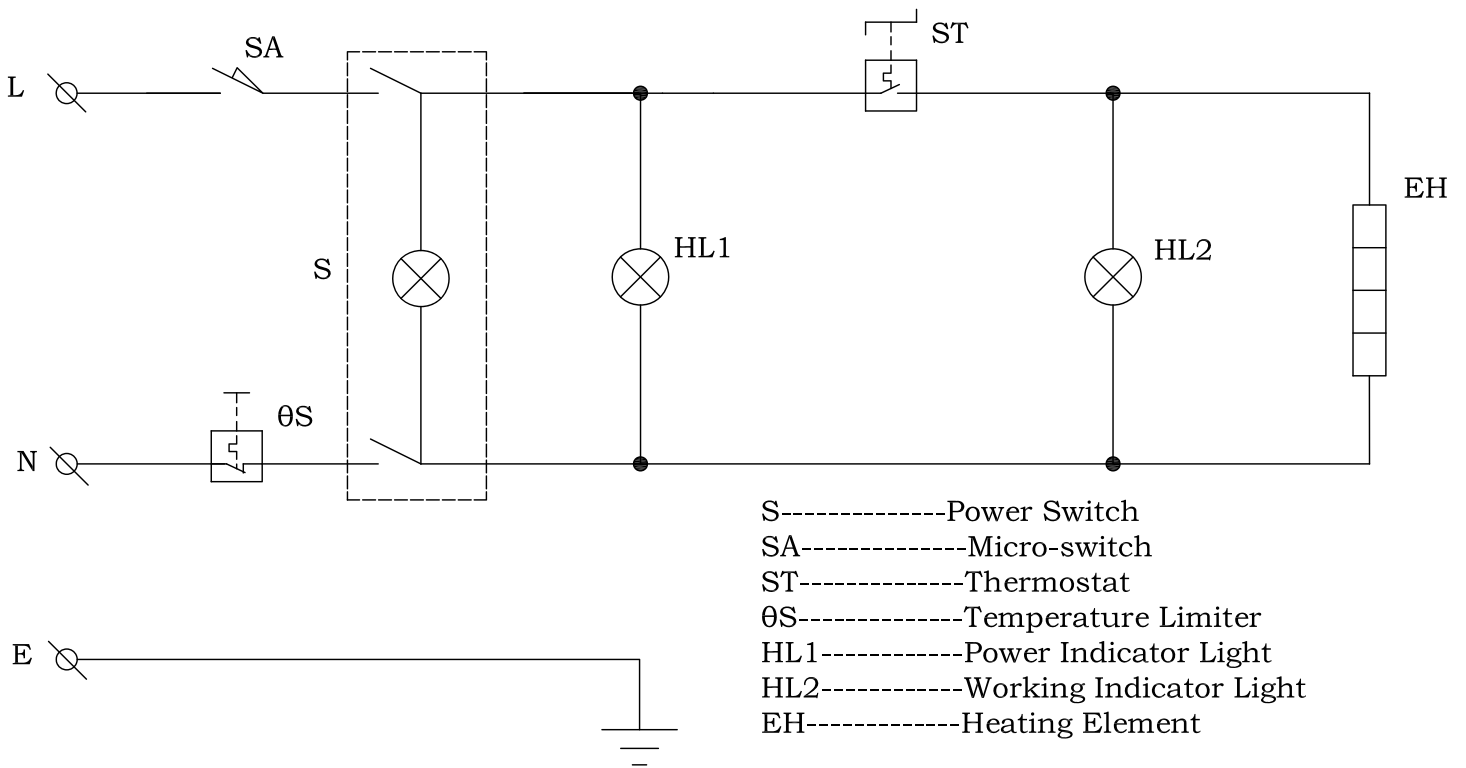

Electrical Schematics

Model CE-CN-3300-F 48522

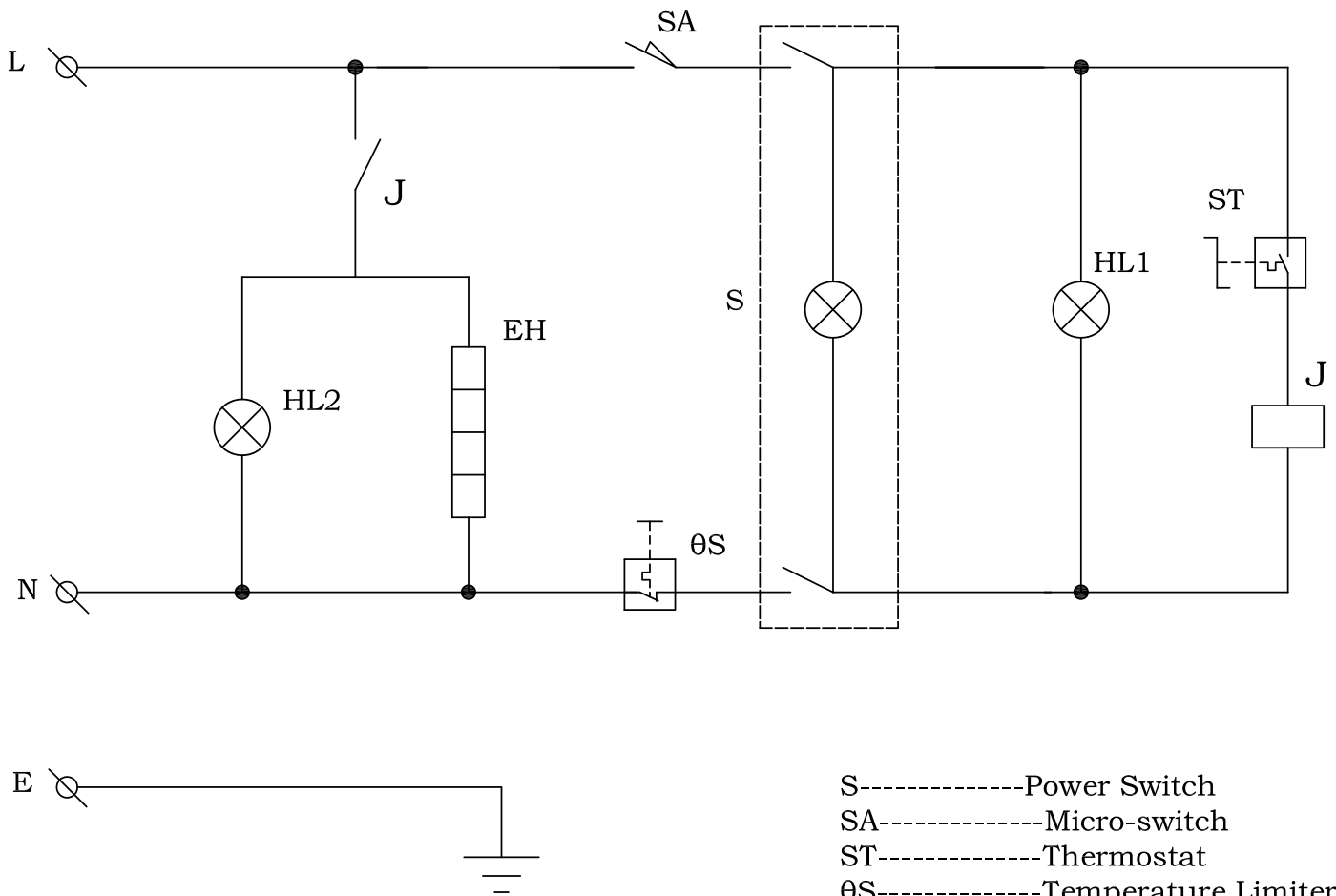

- S-----Power Switch
- SA-----Micro-switch
- ST-----Thermostat
- θS-----Temperature Limiter
- HL1-----Power Indicator Light
- HL2-----Working Indicator Light
- EH-----Heating Element
- J-----Relay

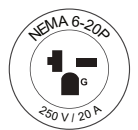



Warranty Registration

Thank you for purchasing an Omcan product. To register your warranty for this product, complete the information below, tear off the card at the perforation and then send to the address specified below. You can also register online by visiting:

Merci d'avoir acheté un produit Omcan. Pour enregistrer votre garantie pour ce produit, complétez les informations ci-dessous, détachez la carte au niveau de la perforation, puis l'envoyer à l'adresse spécifiée ci-dessous. Vous pouvez également vous inscrire en ligne en visitant:

Gracias por comprar un producto Omcan usted. Para registrar su garantía para este producto, complete la información a continuación, cortar la tarjeta en la perforación y luego enviarlo a la dirección indicada a continuación. También puede registrarse en línea en:

<https://omcan.com/warranty-registration/>

For mailing in Canada

Pour postale au Canada

Por correo en Canadá

For mailing in the US

Pour diffusion aux États-Unis

Por correo en los EE.UU.

OMCAN

PRODUCT WARRANTY REGISTRATION

3115 Pepper Mill Court,
Mississauga, Ontario
Canada, L5L 4X5

OMCAN

PRODUCT WARRANTY REGISTRATION

4450 Witmer Industrial Estates, Unit 4,
Niagara Falls, New York
USA, 14305

or email to: service@omcan.com



Purchaser's Information

Name: _____

Address: _____

City: _____ Province or State: _____ Postal or Zip: _____

Country: _____

Dealer from which Purchased: _____

Dealer City: _____ Dealer Province or State: _____

Invoice: _____

Model Name: _____ Model Number: _____

Machine Description: _____

Date of Purchase (MM/DD/YYYY): _____

Would you like to extend the warranty? Yes No

Company Name: _____

Telephone: _____

Email Address: _____

Type of Company:

Restaurant Bakery Deli

Butcher Supermarket Caterer

Institution (specify): _____

Other (specify): _____

Serial Number: _____

Date of Installation (MM/DD/YYYY): _____

Thank you for choosing Omcan | Merci d'avoir choisi Omcan | Gracias por elegir Omcan



Since 1951 Omcan has grown to become a leading distributor of equipment and supplies to the North American food service industry. Our success over these many years can be attributed to our commitment to strengthen and develop new and existing relationships with our valued customers and manufacturers. Today with partners in North America, Europe, Asia and South America, we continually work to improve and grow the company. We strive to offer customers exceptional value through our qualified local sales and service representatives who provide convenient access to over 6,500 globally sourced products.

Depuis 1951 Omcan a grandi pour devenir un des “leaders” de la distribution des équipements et matériel pour l’industrie des services alimentaires en Amérique du Nord. Notre succès au cours de ces nombreuses années peut être attribué à notre engagement à renforcer et à développer de nouvelles et existantes relations avec nos clients et les fabricants de valeur. Aujourd’hui avec des partenaires en Amérique du Nord, Europe, Asie et Amérique du Sud, nous travaillons continuellement à améliorer et développer l’entreprise. Nous nous efforçons d’offrir à nos clients une valeur exceptionnelle grâce à nos ventes locales qualifiées et des représentants de service qui offrent un accès facile à plus de 6500 produits provenant du monde entier.

Desde 1951 Omcan ha crecido hasta convertirse en un líder en la distribución de equipos y suministros de alimentos en América del Norte industria de servicios. Nuestro éxito en estos años se puede atribuir a nuestro compromiso de fortalecer y desarrollar nuevas relaciones existentes con nuestros valiosos clientes y fabricantes. Hoy con socios de América del Norte, Europa, Asia y América del Sur, que trabajan continuamente para mejorar y crecer la empresa. Nos esforzamos por ofrecer a nuestros clientes valor excepcional a través de nuestro local de ventas y representantes de los servicios que proporcionan un fácil acceso a más de 6,500 productos con origen a nivel mundial.

