

Aurora Undercounter Refrigeration, Stainless Steel

ITEM:	59053	59056	59093	59091
MODEL:	FR-CN-0686E-HC	RE-CN-0011E-HC	RE-CN-0015E-HC	RE-CN-0017E-HC



The perfect solution to add cold storage space for frozen products and ingredients conveniently within reach.

This undercounter refrigeration is perfect for cold food storage operations while saving space. Slide it under a counter or work table to utilize its space for storing chilled items. Its durable stainless steel construction is designed to endure frequent use, and its user-friendly controls reduce the time spent adjusting and monitoring settings for peak performance. Additionally, it uses Hydro-carbon R290 refrigerant, which is environmentally friendly and more efficient.

FEATURES:

- Stainless steel interior and exterior
- Refrigeration system keeps food at safe
- Self-closing doors with 90-degree stay-open feature
- Adjustable heavy-duty PVC coated shelves
- Digital control system makes it easy to adjust temperature set point and defrost frequency
- Hydro-carbon R290 refrigerant, which is environmentally friendly and more efficient

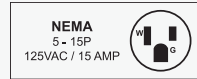
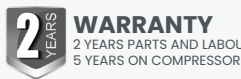
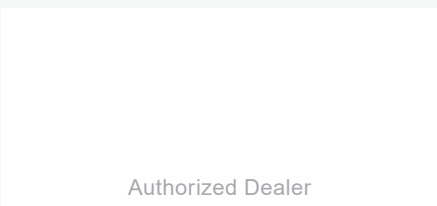

TECHNICAL SPECIFICATION

Features	27" wide with 6.3 cu.ft. (177 L) capacity	48" wide with 6.3 cu.ft. (177 L) capacity	60.2" wide with 15 cu. ft. (425 L) capacity	71.5" wide with 15.5 cu.ft (440L) capacity
Item	59054	59056	59093	59091
Model	RE-CN-0006E-HC	RE-CN-0011E-HC	RE-CN-0015E-HC	RE-CN-0017E-HC
Capacity	6.3 cu.ft. (177 L)	11.3 cu.ft (320 L)	15 cu. ft. (425 L)	15.5 cu.ft (440L)
Number of Doors	1 Swing Door - Solid Door	2 Swing Doors - Solid Doors		3 Swing Doors - Solid Doors
Self-closing Door	Yes			
Number of Shelves	1	2		3
Shelf Capacity (kg/pc)	44 lb. (20 kg.)	88lb. (40kg.)		
Shelf Material	Plastic Coated Steel			
Number of Casters	Yes (4)			
Power	1/6 hp	1/4 hp	285 W	1/5 hp
Amps	1.9 A	2.7 A	2.6 A	1.9 A
Electrical	115V / 60Hz / 1Ph			
Temperature Controller	Digital			
Temperature Range	5 - 0.5°C (41 - 33°F)			
Refrigerant	R290			
Insulation Material	Cyclopentane			
Cooling System	Ventilated			
Defrosting	Automatic			
Interior Dimensions (WDH)	22.2" x 22.8" x 23.5" (565 x 580 x 597 mm)	42.6" x 19.8" x 23.5" (1083 x 504 x 597 mm)	55.6" x 19.84" x 23.5" (1413 x 504 x 597 mm)	66.85" x 19.84" x 23.5" (1698 x 504 x 597mm)
Net Weight	169lb. (77 kg.)	214 lb. (97 kg.)	254 lb. (115 kg.)	297.6 lb. (135 kg.)
Net Dimensions (WDH)	27" x 29.5" x 35.2" (685 x 750 x 895 mm)	47.2" x 29.5" x 35.2" (1200 x 750 x 895 mm)	60.2" X 29.5" X 38.8" (1529 x 750 x 985 mm)	72" x 29.5" x 35.2" (1829 x 750 x 895mm)
Plug Type	NEMA 5-15P			

* This equipment is intended for indoor environment using where ambient temperature do not exceed 24°C(75°F) & 55% relative humidity

TECHNICAL DRAWING

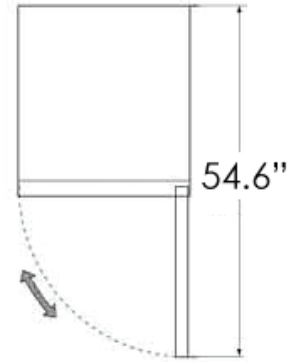
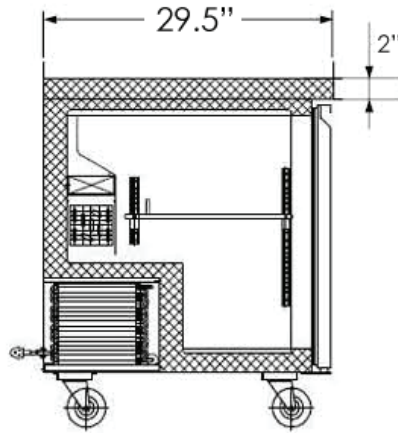
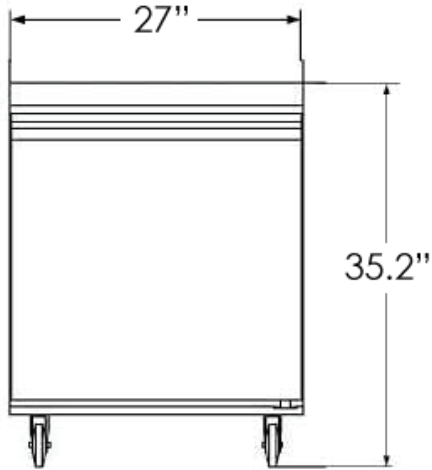

27" wide
59054

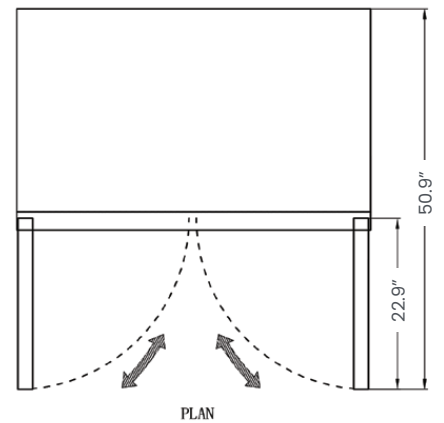
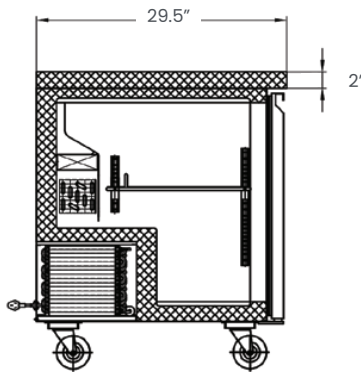
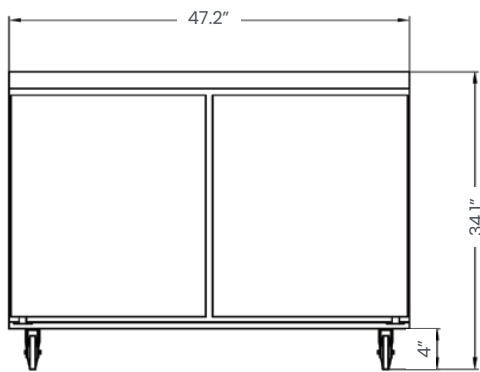

ELEVATION

SECTION VIEW

PLAN

48" wide
59056

TECHNICAL DRAWING

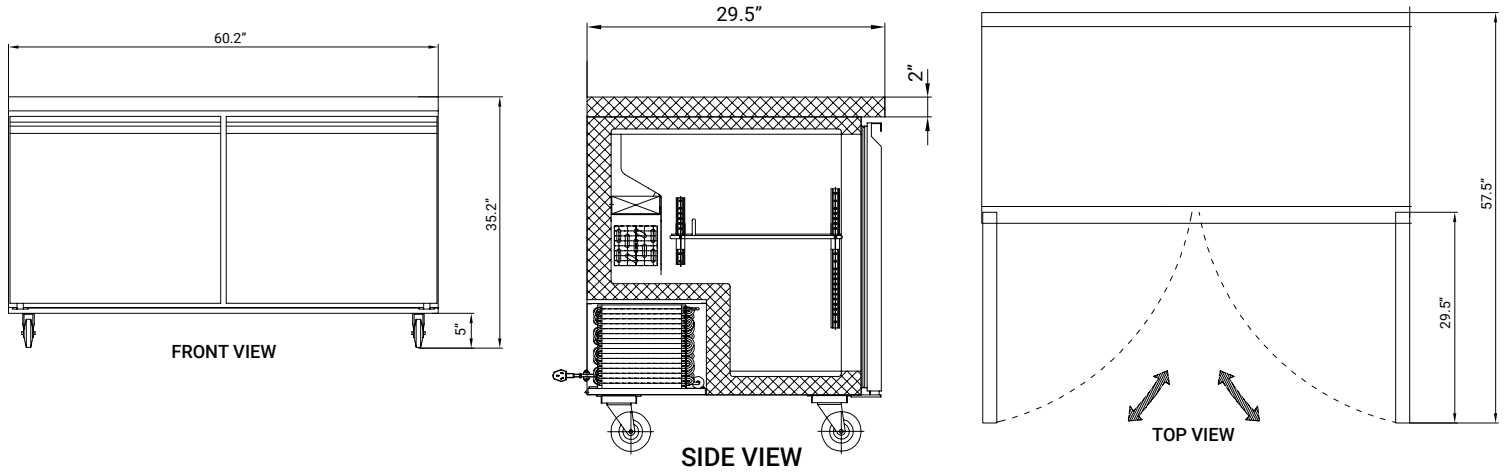

60" wide
59093

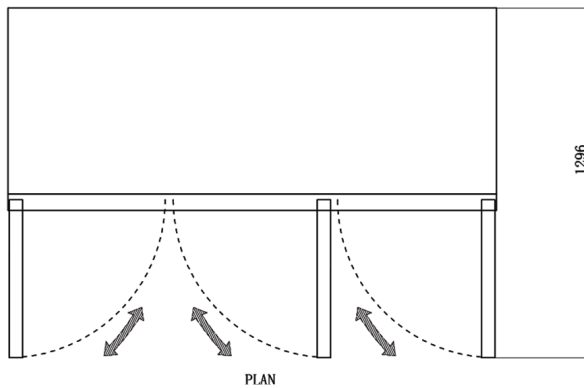
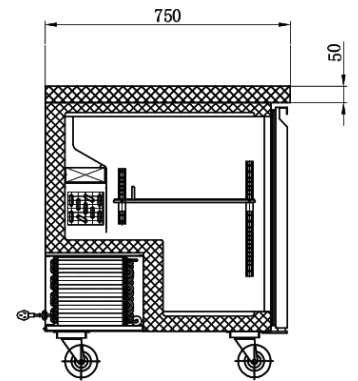
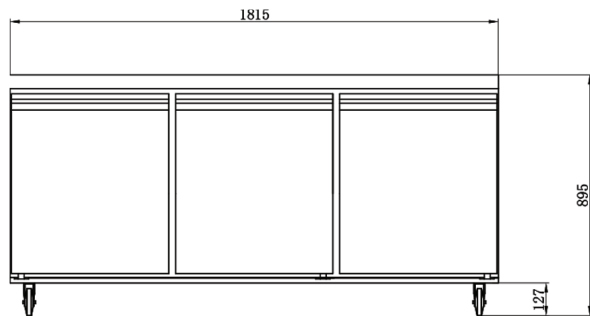

72" wide
59091