



Serving the Food Industry Since 1951

Countertop Fried Food Holding Cabinet

ITEM: 43452
MODEL: FW-CN-0300-C



Keep It Hot. Keep It Crispy.

This Omcan fry dump station keeps fries, onion rings, and more hot and ready during peak hours. A top-mounted heat lamp helps maintain fresh-from-the-fryer quality, making it ideal for snack bars, concessions, and restaurants. The perforated pan and oil tray work together to keep food crisp, while durable stainless steel ensures long-lasting use.

Note: This unit uses radiant heat only and has no adjustable controls. Maximum temperature is 75°C (167°F), but actual holding temperatures may vary with ambient conditions.

Features:

- Stainless steel construction
- Heat lamp for holding fried food
- Removable food pans
- Oil tray underneath
- Salt shaker included

TECHNICAL SPECIFICATION

Item	43452
Model	FW-CN-0300-C
Power	300 W
Electricals	110V / 60 Hz
Max Temperature *	75°C / 167 °F
Net Dimensions (WDH)	26.77" x 27.55" x 31.75" (680 x 700 x 808.45 mm)
Net Weight	109 lbs (49 kg)

*Operation at a max temperature of 75°C (167°F). Actual holding temperatures may vary depending on ambient room conditions

TECHNICAL DRAWING (43452)

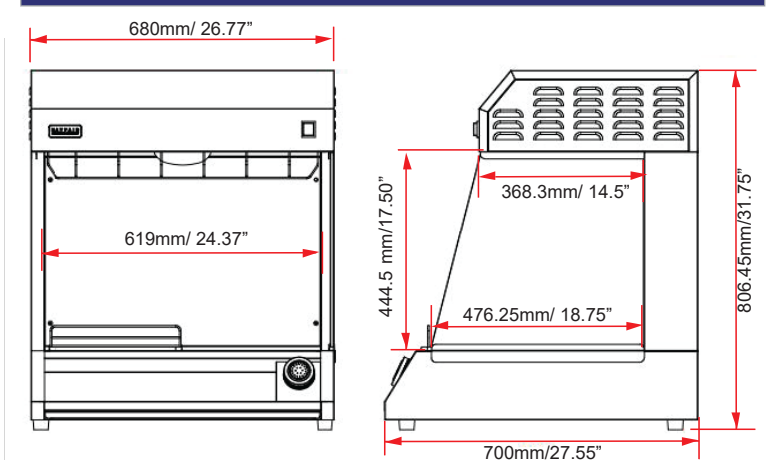

Dimensions rounded up to the nearest tenth inch or millimeter. Specifications subject to change without notice.

Telephone: 1-800-465-0234

Fax: (905) 607-0234

Email: sales@omcan.com

Website: www.omcan.com



Authorized Dealer



Made in China