



Heavy Duty Baking Mixer

Model MX-CN-0060-U

Item 19999

Instruction Manual



Revised - 10/02/2025



Toll Free: 1-800-465-0234
Fax: 905-607-0234
Email: service@omcan.com
www.omcan.com



Table of Contents

Model MX-CN-0060-U

Section	Page
General Information -----	3 - 4
Safety and Warranty -----	4 - 5
Technical Specifications -----	6
Operation -----	6
Maintenance -----	7
Troubleshooting -----	7
Parts Breakdown -----	8 - 9
Electrical Schematics -----	10
Warranty Registration -----	11



General Information

Omcan Manufacturing and Distributing Company Inc., Food Machinery of America, Inc. dba Omcan and Omcan Inc. are not responsible for any harm or injury caused due to any person's improper or negligent use of this equipment. The product shall only be operated by someone over the age of 18, of sound mind, and not under the influence of any drugs or alcohol, who has been trained in the correct operation of this machine, and is wearing authorized, proper safety clothing. Any modification to the machine voids any warranty, and may cause harm to individuals using the machine or in the vicinity of the machine while in operation.

CHECK PACKAGE UPON ARRIVAL

Upon receipt of an Omcan shipment please inspect for external damage. If no damage is evident on the external packaging, open carton to ensure all ordered items are within the box, and there is no concealed damage to the machine. If the package has suffered rough handling, bumps or damage (visible or concealed), please note it on the bill of lading before accepting the delivery and contact Omcan within 24 hours, so we may initiate a claim with the carrier. A detailed report on the extent of the damage caused to the machine must be filled out within three days, from the delivery date shown in the shipping documents. Omcan has no recourse for damaged products that were shipped collect or third party.

Before operating any equipment, always read and familiarize yourself with all operation and safety instructions.

Omcan would like to thank you for purchasing this machine. It's of the utmost importance to save these instructions for future reference. Also save the original box and packaging for shipping the equipment if servicing or returning of the machine is required.

Omcan Fabrication et distribution Compagnie Limitée et Food Machinery d'Amérique, dba Omcan et Omcan Inc. ne sont pas responsables de tout dommage ou blessure causé du fait que toute personne ait utilisé cet équipement de façon irrégulière. Le produit ne doit être exploité que par quelqu'un de plus de 18 ans, saine d'esprit, et pas sous l'influence d'une drogue ou d'alcool, qui a été formé pour utiliser cette machine correctement, et est vêtu de vêtements de sécurité appropriés. Toute modification de la machine annule toute garantie, et peut causer un préjudice à des personnes utilisant la machine ou des personnes à proximité de la machine pendant son fonctionnement.

VÉRIFIEZ LE COLIS DÈS RÉCEPTION

Dès réception d'une expédition d'Omcan veuillez inspecter pour dommages externes. Si aucun dommage n'est visible sur l'emballage externe, ouvrez le carton afin de s'assurer que tous les éléments commandés sont dans la boîte, et il n'y a aucun dommage dissimulé à la machine. Si le colis n'a subi aucune mauvaises manipulations, de bosses ou de dommages (visible ou cachée), notez-le sur le bond de livraison avant d'accepter la livraison et contactez Omcan dans les 24 heures qui suivent, pour que nous puissions engager une réclamation auprès du transporteur. Un rapport détaillé sur l'étendue des dommages causés à la machine doit être rempli dans un délai de trois jours, à compter de la date de livraison indiquée dans les documents d'expédition. Omcan n'a aucun droit de recours pour les produits endommagés qui ont été expédiés ou cueillis par un tiers transporteur.

Avant d'utiliser n'importe quel équipement, toujours lire et vous familiariser avec toutes les opérations et les

General Information

consignes de sécurité.

Omcan voudrais vous remercier d'avoir choisi cette machine. Il est primordial de conserver ces instructions pour une référence ultérieure. Également conservez la boîte originale et l'emballage pour l'expédition de l'équipement si l'entretien ou le retour de la machine est nécessaire.

Omcan Empresa De Fabricacion Y Distribucion Inc. Y Maquinaria De Alimentos De America, Inc. dba Omcan y Omcan Inc. no son responsables de ningun daño o perjuicio causado por cualquier persona inadecuada o el uso descuidado de este equipo. El producto solo podra ser operado por una persona mayor de 18 años, en su sano juicio y no bajo alguna influencia de droga o alcohol, y que este ha sido entrenado en el correcto funcionamiento de esta máquina, y ésta usando ropa apropiada y autorizada. Cualquier modificación a la máquina anula la garantía y puede causar daños a las personas usando la máquina mientras esta en el funcionamiento.

REVISE EL PAQUETE A SU LLEGADA

Tras la recepcion de un envio Omcan favor inspeccionar daños externos. Si no hay daños evidentes en el empaque exterior, Habra el carton para asegurarse que todos los articulos solicitados estén dentro de la caja y no encuentre daños ocultos en la máquina. Si el paquete ha sufrido un manejo de poco cuidado, golpes o daños (visible o oculto) por favor anote en la factura antes de aceptar la entrega y contacte Omcan dentro de las 24 horas, de modo que podamos iniciar una reclamación con la compañía. Un informe detallado sobre los daños causados a la máquina debe ser llenado en el plazo de tres días, desde la fecha de entrega que se muestra en los documentos de envío. Omcan no tiene ningun recurso por productos dañados que se enviaron a recoger por terceros.

Antes de utilizar cualquier equipo, siempre leer y familiarizarse con todas las instrucciones de operación y seguridad.

Omcan quisiera darles las gracias por la compra de esta máquina. Es de la máxima importancia para guardar estas instrucciones para referencias en el futuro. También guarde la caja original y el embalaje para envío del equipo si el mantenimiento o la devolución de la máquina es necesaria.

Safety and Warranty

ATTENTION

- New user or repairing this product must be performed by the experts or qualified person or those who have gotten the license of installation, or those who are authorized by the manufacturer.
- When installation or maintenance, please obey the following instructions carefully to ensure the safety use of this appliance.
- Please keep this instruction manual for future reference, or hand it to next user.
- Put off the package to make sure none of the parts is missing or damaged. If there is any doubt about the



Safety and Warranty

product, please do not use it, and consult it to the experts.

- Keep the packing material out of reach of the children to avoid accident (especially the plastic bag, screw etc).
- This appliance could be only operated by the person who is familiar with the unit.
- When not using the appliance or the operator is absent, please turn off the unit to avoid any accidental injury or damage.
- When it needs to be repaired, please ask for expert, and use the original fitted spare part. It will be dangerous if not following the above requirements.
- This appliance is just for commercial using, not for any other use, otherwise, it may be dangerous.
- Do not rinse the equipment with water directly.
- Clean the surface of stainless steel periodically with appropriate method to prevent any damage brought by oxidization or any other chemical interference.

RESIDENTIAL USERS: vendor assumes no liability for parts or labor coverage for component failure or other damages resulting from installation in non-commercial or residential applications. The right is reserved to deny shipment for residential usage; if this occurs, you will be notified as soon as possible.

1 YEAR PART AND LABOR WARRANTY

Within the warranty period, contact Omcan Inc. at 1-800-465-0234 to schedule an Omcan authorized service technician to repair the equipment locally.

Unauthorized maintenance will void the warranty. Warranty covers electrical and part failures, not improper use.

Please see <https://omcan.com/disclaimer> for complete info.

WARNING:

The packaging components are classified as normal solid urban waste and can therefore be disposed of without difficulty.

In any case, for suitable recycling, we suggest disposing of the products separately (differentiated waste) according to the current norms.

DO NOT DISCARD ANY PACKAGING MATERIALS IN THE ENVIRONMENT!

Technical Specifications

Model	MX-CN-0060-U
Item Number	19999
Power	3 - 3.75 HP / 2.2 - 2.8 kW
Mixing Speed	79 / 109 / 143 / 216 RPM
Capacity	60 QT / 15 Gal
Kneading Capacity	44 lbs. / 20 kgs.
Electrical	220V / 60Hz / 3
Weight	1078 lbs. / 489 kgs.
Packaging Weight	1230 lbs. / 558 kgs.
Dimensions	24.4" x 40.4" 56.3" / 615 x 1026 x 1430mm
Packaging Dimensions	45" x 30" x 66" / 1143 x 762 1676mm

Operation

- Before use, check whether the power supply corresponds to that required by the machine, check whether the external earthed wire is reliably connected.
- The machine which 3 phase motor must be checked whether the machine rotates in the direction indicated by the rotation mark. If the rotation direction is wrong, exchange the two of the three livewires each other.
Note: for test of machine, mixing tools should never be installed, otherwise they would fall out in order to avoid damage to machine parts because of wrong rotation direction.
- Select speed and agitator:
 - Spiral agitator: it is suitable for mixing dough and sticky solid food, the weight of flour must refer to the mark, the capacity of water is 47%~50% of the flour's, and the machine is available for low speed.
 - Vaned disk agitator: it is suitable for thin pieces, powdered and mushy food, like stuffing, and available for middle speed.
 - Beater: it is suitable for cream and eggs beating, and available for high speed.**Caution: stop the machine to change speed, do not mix dough at middle or high speed.**
- Speed changing operation: the unit has an adapted motor and mechanism's concerted action to change speed.
- Bowl lift: the bowl is driven by motor to raise or descend up to the requested position (top point, bottom point, and stop point). The operating method is:
 - Adjust the lifting handle to 45° comparing the horizontal line, and then raise the bowl.
 - Adjust the lifting handle to the horizontal line, and then descend the bowl.
 - When the lifting handle is between the two positions, the bowl will stop lifting.**Note: when assembling an agitator, in order to avoid falling, the backing pin on the mixing shaft must slip into the L-shaped slot on the agitator.**
- The mixer is equipped with a timer, so you can select the timer control as needed. If you use the timer, you can set the needed time on the timer.

Maintenance

1. After use every time, clean the bowl and agitators etc., carefully, in order to ensure the machine clean and hygienic.
2. Lubricate the lifting slideways with a small amount of oil regularly.
3. The gearbox is lubricated with special grease that will be sufficient for six months. When added or replaced grease, it is necessary to remove the upper cover and the cover of the bearing seat.

Troubleshooting

Trouble	Probable Cause	Remedy
The mixing shaft do not rotate after switching on.	Electric connectors are loose.	Check the electric circuit, tighten those loose connectors.
Oil leakage.	Oil seals are worn out.	Replace those oil seals.
The lifting handle is too heavy.	Guideways are corrosive.	Clean and oil the guideways.
	The lifting screw, bevel gear and handwheel shaft etc. is dry.	Oil them.
Temperature rise of motor is too high, the revolution is lower.	Lack of voltage.	Check the supply voltage.
	Over load.	Less load.
	The working speed selected is too high or agitator is not suitable.	Select a suitable speed and agitator as mentioned above.

Parts Breakdown

Model MX-CN-0060-U 19999

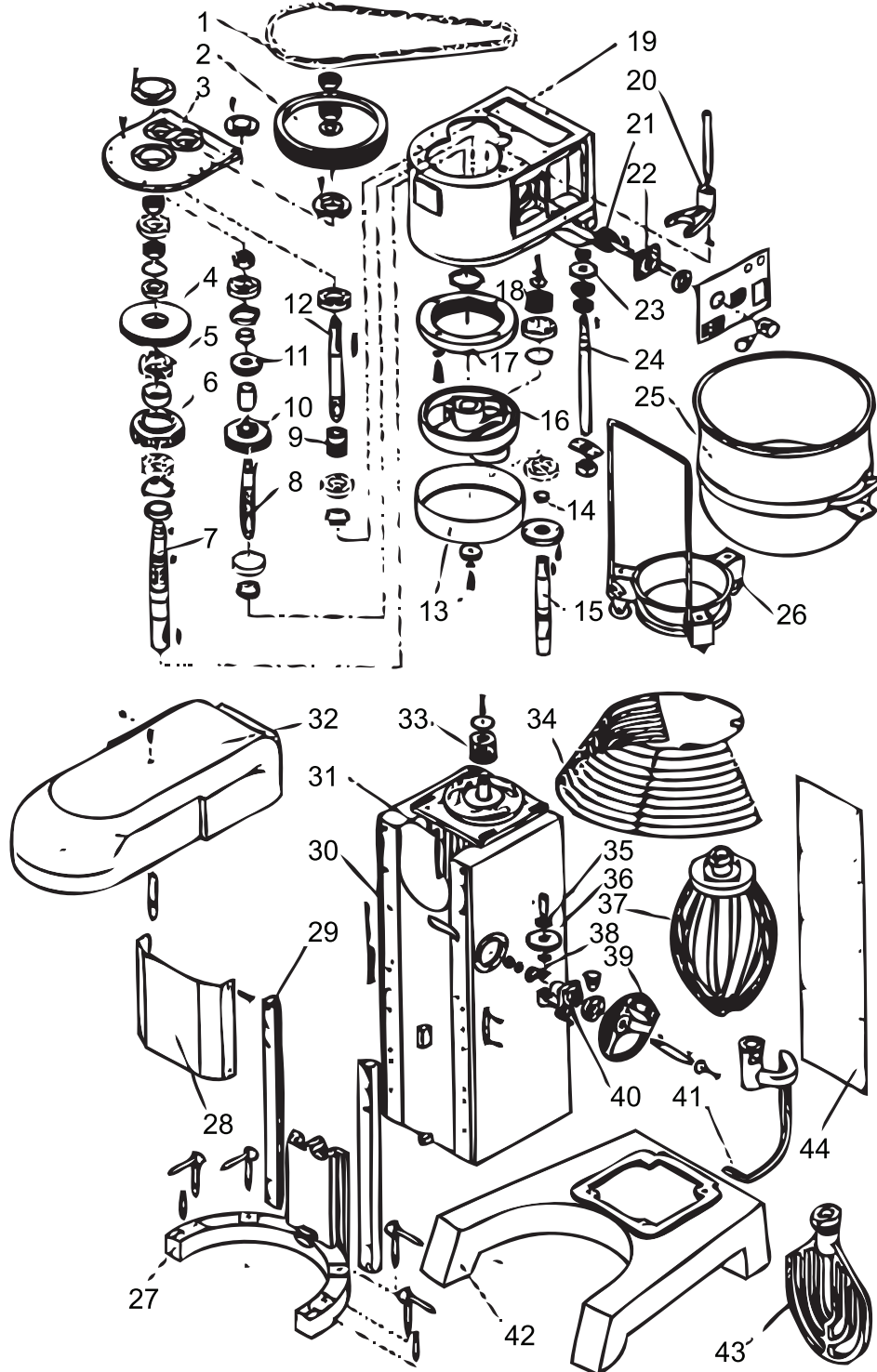

Parts Breakdown

Model MX-CN-0060-U 19999

Item No.	Description	Position	Item No.	Description	Position	Item No.	Description	Position
24627	BELT FOR 19999	1	24642	ECCENTRICITY BASE FOR 19999	16	24657	MOTOR FOR 19999	31
24628	BIG BELT PULLEY FOR 19999	2	24643	ANNULAR GEAR Z=72 FOR 19999	17	24658	TOP COVER FOR 19999	32
24629	CASE COVER FOR 19999	3	24644	GEAR Z=22 FOR 19999	18	24659	BELT PULLEY FOR 19999	33
24630	GEAR Z=60 FOR 19999	4	24645	CASE FOR 19999	19	24660	PROTECTING SHIELD FOR 19999	34
24631	JOINTER FOR 19999	5	24646	FORK FOR 19999	20	24661	GEAR Z=22 FOR 19999	35
24632	GEAR Z=48 FOR 19999	6	24647	FORK GEAR FOR 19999	21	24662	GEAR Z=36 FOR 19999	36
24633	MAIN SHAFT FOR 19999	7	24648	RACK FOR 19999	22	24663	WIRE WHIP FOR 19999	37
24634	MIDDLE SHAFT FOR 19999	8	24649	GEAR Z=27 FOR 19999	23	24664	GEAR Z=22 FOR 19999	38
24635	SMALL GEAR Z=15 FOR 19999	9	24650	SCREW POLE FOR 19999	24	24665	HANDLE WHEEL FOR 19999	39
24636	GEAR Z=40 FOR 19999	10	24651	BOWL FOR 19999	25	24666	RACK FOR 19999	40
24637	GEAR Z=26 FOR 19999	11	24652	TRAILER FOR 19999	26	24667	DOUGH ARM FOR 19999	41
24638	SHAFT FOR 19999	12	24653	BOWL SUPPORTER FOR 19999	27	24668	BOTTOM BASE FOR 19999	42
24639	OIL COLLECTING TRAY FOR 19999	13	24654	FRONT COVER FOR 19999	28	24669	FLAT BEATER FOR 19999	43
24640	OIL SEALING FOR 19999	14	24655	PRESSURE PLATE FOR 19999	29	24670	BACK COVER FOR 19999	44
24641	MIXING SHAFT FOR 19999	15	24656	PEDESTAL FOR 19999	30			

Electrical Schematics

Model MX-CN-0060-U 19999

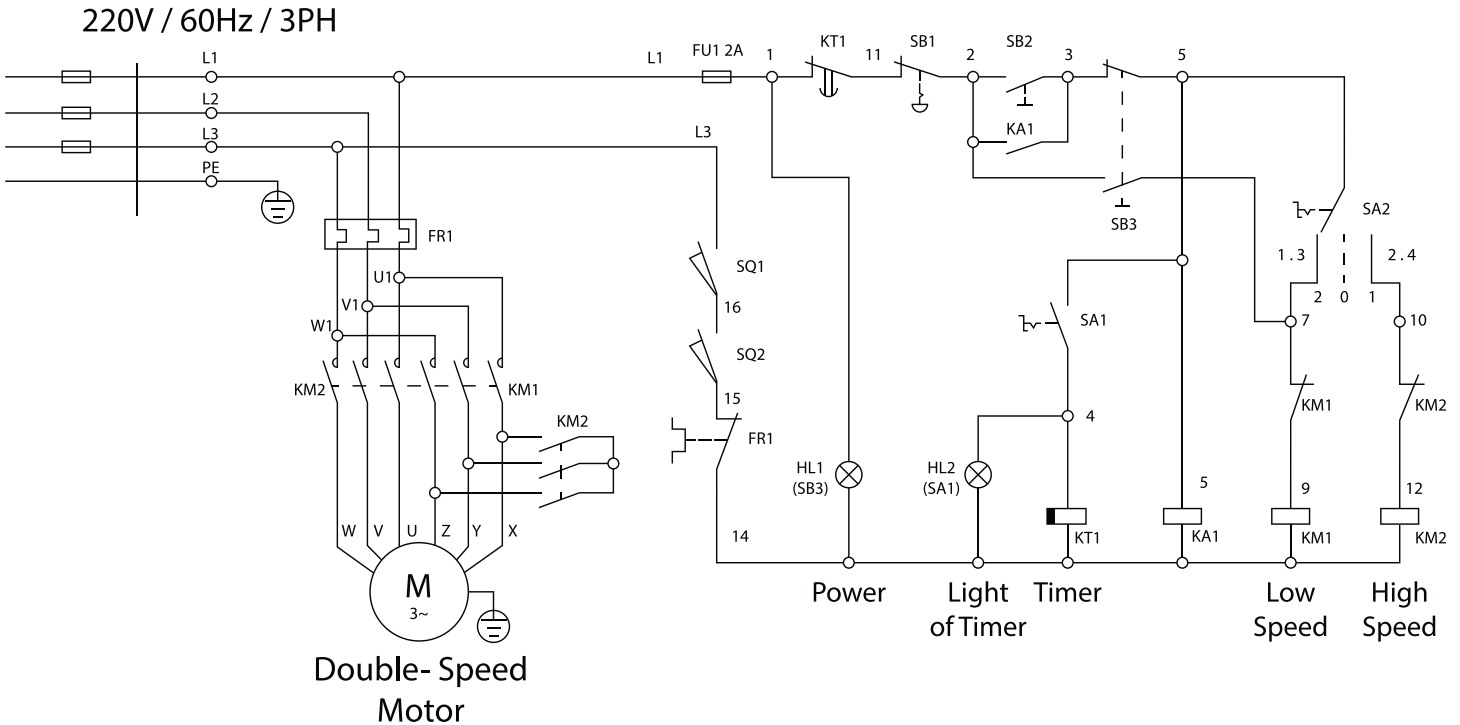

Position	Description	Position	Description	Position	Description
FR	THERMORELAY.	KT1	TIME DELAY DEVICE.	SB2	START BUTTON.
FU	FUSIONER.	M	DOUBLE SPEED MOTOR.	SB3	SWITCH WITH LIGHT.
KA1	SMALL POWER RELAY AND SEAT.	SA1	SWITCH WITH LIGHT.	SQ1/2	JOURNEY SWITCH.
KM1-KM2	CONTACTOR.	SA2	GENERAL CHANGEOVER SWITCH.		
KM2	AUXILIARY CONTACT.	SB1	EMERGENCY STOP BUTTON.		



Warranty Registration

Thank you for purchasing an Omcan product. To register your warranty for this product, complete the information below, tear off the card at the perforation and then send to the address specified below. You can also register online by visiting:

Merci d'avoir acheté un produit Omcan. Pour enregistrer votre garantie pour ce produit, complétez les informations ci-dessous, détachez la carte au niveau de la perforation, puis l'envoyer à l'adresse spécifiée ci-dessous. Vous pouvez également vous inscrire en ligne en visitant:

Gracias por comprar un producto Omcan usted. Para registrar su garantía para este producto, complete la información a continuación, cortar la tarjeta en la perforación y luego enviarlo a la dirección indicada a continuación. También puede registrarse en línea en:

<https://omcan.com/warranty-registration/>

For mailing in Canada

Pour postale au Canada

Por correo en Canadá

For mailing in the US

Pour diffusion aux États-Unis

Por correo en los EE.UU.

OMCAN

PRODUCT WARRANTY REGISTRATION

3115 Pepper Mill Court,
Mississauga, Ontario
Canada, L5L 4X5

OMCAN

PRODUCT WARRANTY REGISTRATION

4450 Witmer Industrial Estates, Unit 4,
Niagara Falls, New York
USA, 14305

or email to: service@omcan.com



Purchaser's Information

Name: _____

Address: _____

City: _____ Province or State: _____ Postal or Zip: _____

Country: _____

Dealer from which Purchased: _____

Dealer City: _____ Dealer Province or State: _____

Invoice: _____

Model Name: _____ Model Number: _____

Machine Description: _____

Date of Purchase (MM/DD/YYYY): _____

Would you like to extend the warranty? Yes No

Company Name: _____

Telephone: _____

Email Address: _____

Type of Company:

Restaurant Bakery Deli

Butcher Supermarket Caterer

Institution (specify): _____

Other (specify): _____

Serial Number: _____

Date of Installation (MM/DD/YYYY): _____

Thank you for choosing Omcan | Merci d'avoir choisi Omcan | Gracias por elegir Omcan



Since 1951 Omcan has grown to become a leading distributor of equipment and supplies to the North American food service industry. Our success over these many years can be attributed to our commitment to strengthen and develop new and existing relationships with our valued customers and manufacturers. Today with partners in North America, Europe, Asia and South America, we continually work to improve and grow the company. We strive to offer customers exceptional value through our qualified local sales and service representatives who provide convenient access to over 6,500 globally sourced products.

Depuis 1951 Omcan a grandi pour devenir un des "leaders" de la distribution des équipements et matériel pour l'industrie des services alimentaires en Amérique du Nord. Notre succès au cours de ces nombreuses années peut être attribué à notre engagement à renforcer et à développer de nouvelles et existantes relations avec nos clients et les fabricants de valeur. Aujourd'hui avec des partenaires en Amérique du Nord, Europe, Asie et Amérique du Sud, nous travaillons continuellement à améliorer et développer l'entreprise. Nous nous efforçons d'offrir à nos clients une valeur exceptionnelle grâce à nos ventes locales qualifiées et des représentants de service qui offrent un accès facile à plus de 6500 produits provenant du monde entier.

Desde 1951 Omcan ha crecido hasta convertirse en un líder en la distribución de equipos y suministros de alimentos en América del Norte industria de servicios. Nuestro éxito en estos años se puede atribuir a nuestro compromiso de fortalecer y desarrollar nuevas relaciones existentes con nuestros valiosos clientes y fabricantes. Hoy con socios de América del Norte, Europa, Asia y América del Sur, que trabajan continuamente para mejorar y crecer la empresa. Nos esforzamos por ofrecer a nuestros clientes valor excepcional a través de nuestro local de ventas y representantes de los servicios que proporcionan un fácil acceso a más de 6,500 productos con origen a nivel mundial.

