

# LAZY SUSAN PRODUCT ACCUMULATOR

MODEL: SS-LS

sealersales

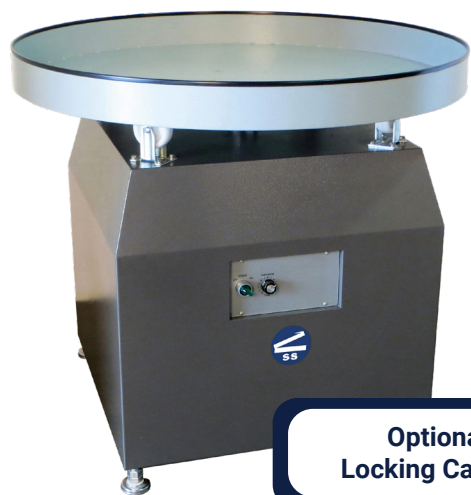

Optional  
Locking Casters

Great for Accumulating Small Packages

- Available in 36", 48", or 60" diameter
- Turntable speeds adjusts from 0 - 12 RPM
- Plugs into any standard 110V outlet
- Includes adjustable leveling screws
- Holds up to 200-lbs of product
- 3" deep table top
- Options: locking casters, stainless steel body

Video Demo →



For a reliable, convenient solution to manage smaller packaged and shrink-wrapped products as they exit your machine, consider our **Lazy Susan Product Accumulating Turntable**. The turntable offers adjustable speeds from 0 to 12 rotations per minute, allowing you to fine-tune the pace to suit your needs.

This works as an ideal alternative to conveyors—where smaller items might fall through. The lazy susan turntable easily plugs into any standard 110-volt outlet. The turntable is built with high-quality bearing rollers for smooth, consistent spinning, while adjustable leveling bolts make it compatible with any conveyor line height.

SPECIFICATIONS	SS-36LS	SS-48LS	SS-60LS
VOLTAGE	110V / 5 AMP	110V / 5 AMP	110V / 10 AMP
TABLE DIAMETER	36"	48"	60"
TABLE DEPTH	3"	3"	3"
SPEED	0-12 RPM	0-12 RPM	0-12 RPM
MAX WEIGHT	200-LB	200-LB	200-LB
STAINLESS STEEL AVAILABLE?	YES	YES	YES
GROSS WEIGHT	250-LBS	300-LBS	375-LBS
SHIPPING DIMENSIONS	48" X 40" X 44"	50" X 40" X 55"	60" X 40" X 66"

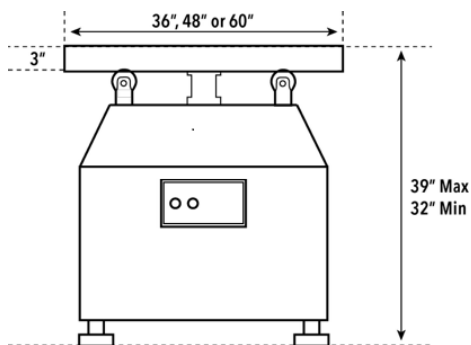

Place the lazy susan at the end of any production line or shrink tunnel to catch finished products.