

Pasta Cooker Natural Gas

ITEM:	49099	49100	49097	49098
MODEL:	CE-IT-0090	CE-IT-0090PLUS	CE-IT-0045	CE-IT-0045PLUS

49099



49100



Unmatched Performance and Precision

The most versatile pasta cookers on the market today, single burner models are great for cooking fresh, dry or partially cooked refrigerated pasta, and double burner models are great for cooking frozen pasta due to fast recovery times. These pasta cookers are not limited to pasta, and can cook items such as rice, vegetables, potato and seafood.

Tanks are stamped from a single piece of AISI #316 stainless steel, and is highly resistant to corrosion due to salt water. A blanket of ceramic fiber insulates each tank, virtually eliminating hot surfaces while providing better efficiency and performance.

Burner design concentrates heat at the rear, and creates a natural convective flow that stirs the pasta without need for manual tossing. This also moves starches into a skim drain, keeping the water starch free.

*LPG Conversion Kit included

- Durable Construction
- Made of AISI 304 grade stainless steel, fully rounded corners
- Perforated tops
- Baskets rest on perforated tops with incorporated channels for drainage (Baskets sold separate)
- Stainless steel burners
- Burners in stainless steel with stabilized flame
- Double burner models for cooking from frozen PLUS models feature double burners for faster cooking (49100, 49098)
- Includes LPG conversion kit
- Auto starch removal
- Corrosion resistant
- Convective design stirs itself while cooking Insulated tanks prevent injuries
- Gas pressure regulator not included, and must be installed by certified technician

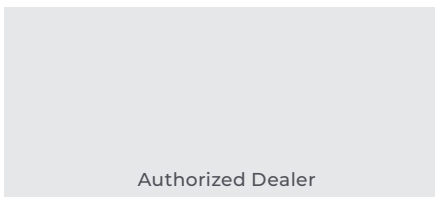



49097



49098

Technical Specification				
Item	49099	49100	49097	49098
Model	CE-IT-0090	CE-IT-0090PLUS	CE-IT-0045	CE-IT-0045PLUS
Material	Stainless Steel			
Thermal Power	95,000 BTU/hr	156,000 BTU/hr	47,500 BTU/hr	78,000 BTU/hr
Tank Volume	2 x 11.89 Gal	2x 11.89 Gal	1 x 11.89 Gal	1 x 11.89 Gal
Net Weight	264.5 lb. (120 kg.)	271 lb. (123kg.)	143.3 lb. (65 kg.)	147.7 lbs. (67 kg)
Net Dimensions	35.43" x 35.43" x 45.78" (900 x 900 x 1100/1163 mm)	35.43" x 35.43" x 45.78" (900 x 900 x 1100/1163 mm)	17.72" x 35.43" x 43.30" (450 x 900 x 1100/1163 mm)	17.72" x 35.43" x 43.30" (450 x 900 x 1100/1163 mm)
Gross Weight	302 lb. (137 kg.)	308.6 lbs. (140 kg)	170 lbs. (77 kg)	174 lbs. (79 kg)
Gross Dimensions	39.3" x 43.3" x 51.2" (1000 x 1100 x 1300 mm)	39.3" x 43.3" x 51.2" (1000 x 1100 x 1300 mm)	23.6" x 43.3" x 51.2" (600 x 1100 x 1300 mm)	23.6" x 43.3" x 51.2" (600 x 1100 x 1300 mm)

Technical Drawing

49097

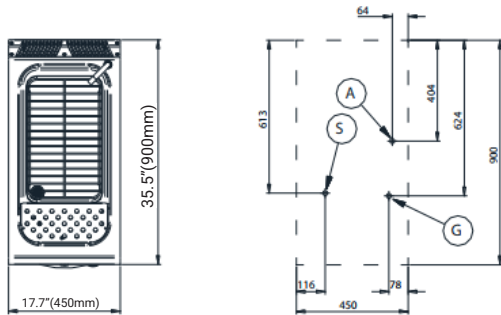
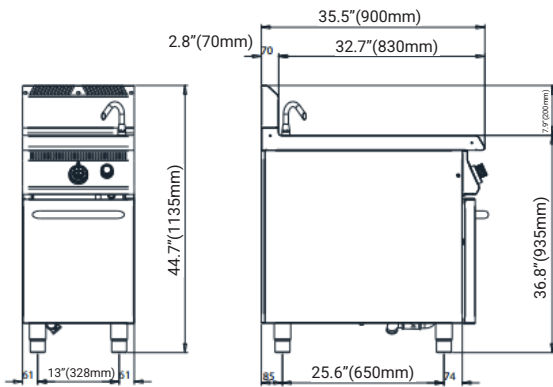

- A = Carico acqua \varnothing 1/2"
Water supply \varnothing 1/2"
- S = Scarico acqua \varnothing 1"
Water drain \varnothing 1"
- G = Gas \varnothing 1/2"

49098

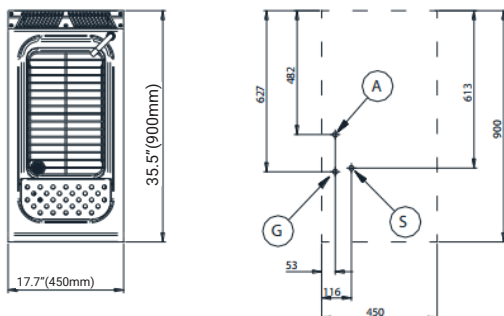
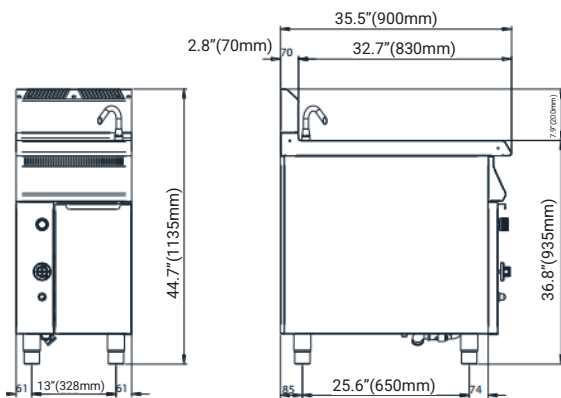

- A = Carico acqua \varnothing 1/2"
Water supply \varnothing 1/2"
- S = Scarico acqua \varnothing 1"
Water drain \varnothing 1"
- G = Gas \varnothing 1/2"

Technical Drawing

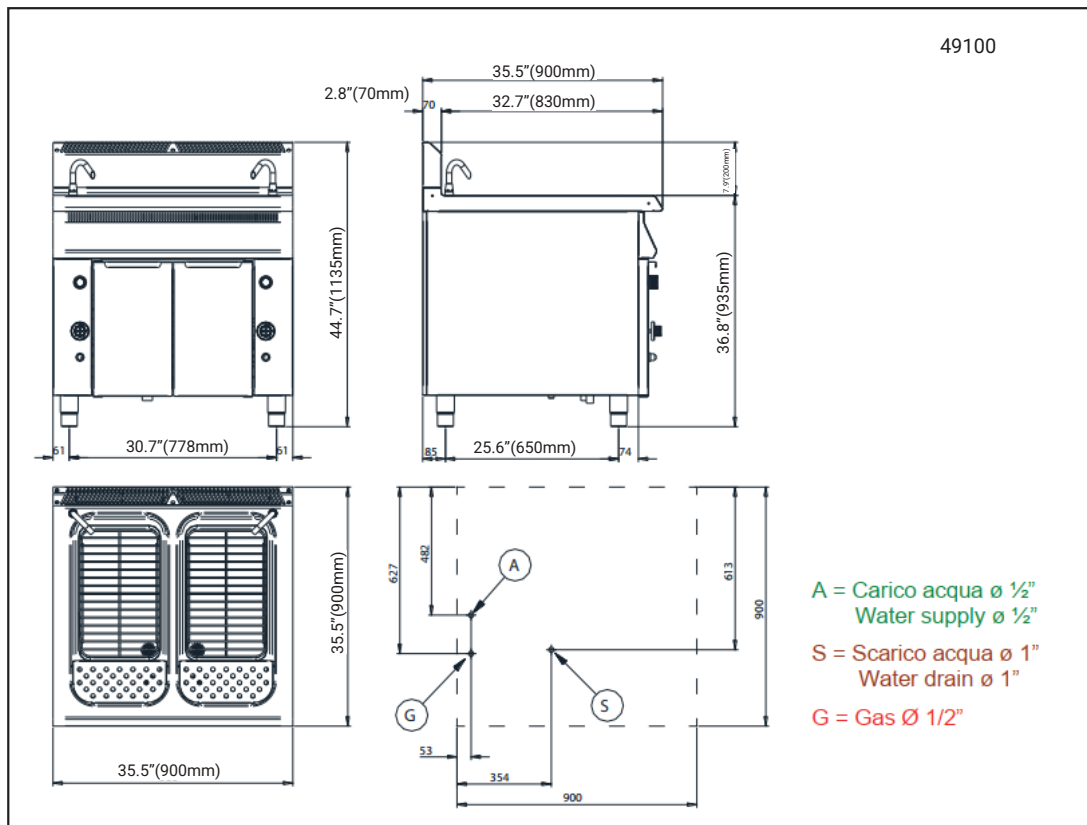
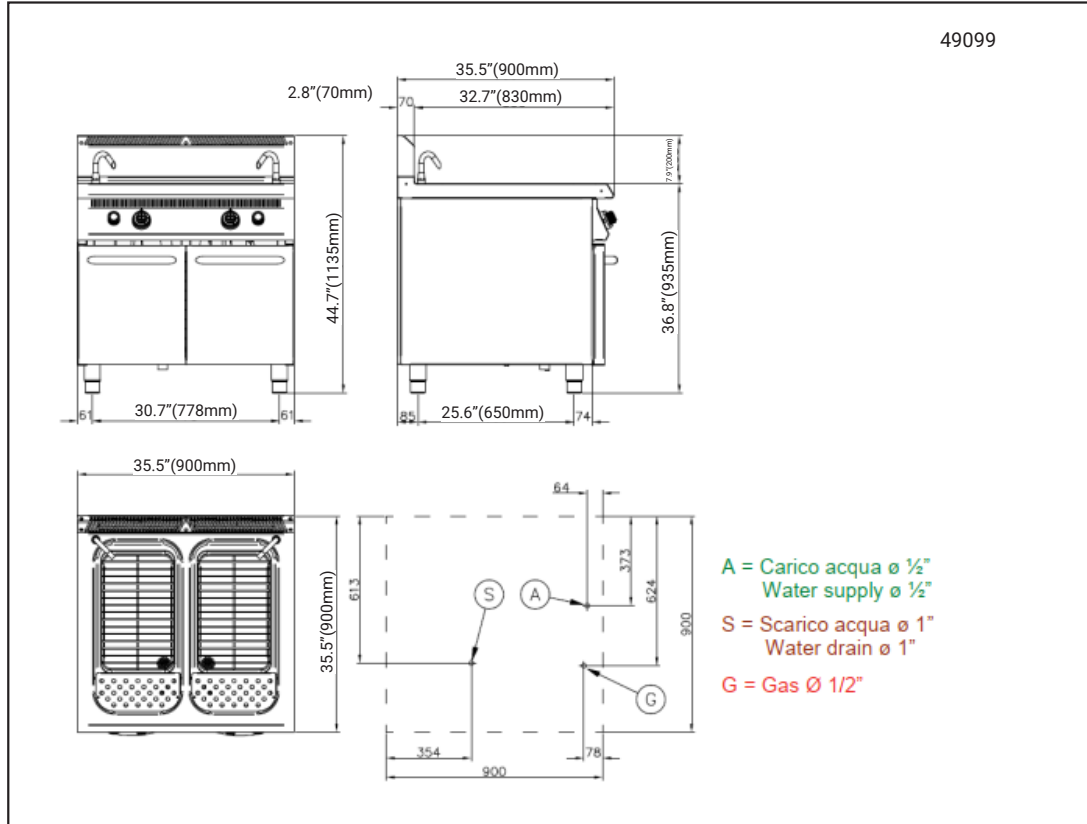

Accessories- Baskets



1/1 (49149)

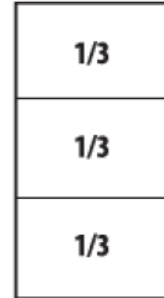
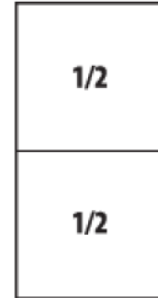
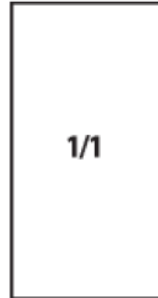

1/2 (49150)

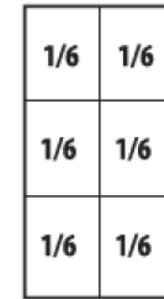
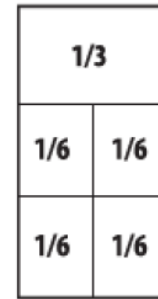
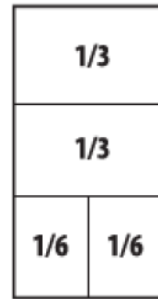

1/3 (49106)



1/6L (49107)



1/6R (49108)



1/6C (49151)

Specification

Item	49149	49150	49106	49107	49108	49151
Shape	Rectangular	Rectangular	Rectangular	Rectangular	Rectangular	Round
Handle	Double	Double	Double	Left	Right	Single
Size	1/1	1/2	1/3	1/6L	1/6R	1/6C
Weight	7 lb (3.1kg)	3 lb (1.3kg)	3.97 lb (1.8kg)	2.43 lb (1.1kg)	2.43 lb (1.1kg)	3 lb (1.3kg)
Dimensions	20" x 12" x 9" (508 x 305 x 229 mm)	10" x 12" x 9" (254 x 305 x 229 mm)	11.3" x 6.4" x 8.4" (287 x 163 x 213 mm)	6.4" x 5.6" x 8.4" (163 x 142 x 213 mm)	6.4" x 5.6" x 8.4" (163 x 142 x 213 mm)	7" x 7" x 9.5" (178 x 178 x 241 mm)

Accessories- Auto Lifters

Controlled by advanced intuitive controls, these auto lifters allow for consistent pasta with the convenience of “set and forget”. Great for busy kitchens where staff must multi-task, and eliminates risk of over/undercooking.

Up to two auto lifters can be installed onto each pasta cooker (one on each side), allowing a maximum of 6 baskets to be operated on automated timers.

**Please note that due to the auto lifter attachment arm taking up extra space, the baskets used in this configuration are a different size from the non-lifter variants. Only compatible lifter baskets may be used with the autolifters.*

**Comes without plug*



Auto Lifter (3 Basket Lifter)

Item	49164
Capacity	3
Power	0.8 kW
Electricals	230 V / 60 Hz / 1 Ph
Weight	55 lb (25 kg)
Dimensions	8" x 36" x 46" (203 x 914 x 1168 mm)

*Item can be installed on left or right side

Auto Lifter Baskets

Item	49158	49159
Shape	Rectangular	Rectangular
Handle	Left	Right
Size	1/6	1/6
Weight	3 lb (1.3kg)	3 lb (1.3kg)
Dimensions	20" x 12" x 9" (508 x 305 x 229 mm)	10" x 12" x 9" (254 x 305 x 229 mm)

