



SERVING THE FOOD INDUSTRY SINCE 1951

Reach-In Beer Bottle Coolers

ITEM:	50038	50039	50040	50041
MODEL:	BB-CN-0005-HC	BB-CN-0014-HC	BB-CN-0017-HC	BB-CN-0026-HC



50041- 95"



50040- 65"



50039- 50"

50038- 26"



Built to meet the high demands of any bar, pub, or restaurant.

Our reach-in commercial bottle coolers deliver durability, efficiency, and convenience, with automatic defrost, a built-in opener, and cap catcher. The heavy-duty black vinyl exterior and aluminum-coated interior ensure easy cleaning, while a stainless steel locking lid adds security. An epoxy-coated evaporator resists corrosion, and a mechanical controller allows simple temperature adjustment for optimal beverage cooling

- Wear-resistant black vinyl Exterior
- Aluminum coated Interior
- Stainless steel locking lid for security & durability
- Epoxy-coated evaporator prevents corrosion
- Removable bottle opener & cap catcher
- Mechanical controller with adjustable temperature (coldest to warmest)

Telephone: 1-800-465-0234

Fax: (905) 607-0234

Email: sales@omcan.com

Website: www.omcan.com



Authorized Dealer



Made in China

(Version 2025.8)

Page 1 / 4

TECHNICAL SPECIFICATION				
Features	26" wide with 5 cu.ft. capacity	50" wide with 13 cu.ft. capacity	65" wide with 17 cu.ft. capacity	95" wide with 20.5 cu. ft. capacity
Item	50038	50039	50040	50041
Model	BB-CN-0005-HC	BB-CN-0014-HC	BB-CN-0017-HC	BB-CN-0026-HC
Capacity	5 cu. ft./ 141 L	13.5 cu. ft./ 382 L	17.23 cu. ft./ 488 L	20.5 cu. ft./580 L
Product Capacity	12 oz bottles-4.5 cases 12 oz cans-6 cases	12 oz bottles-16.5 cases 12 oz cans-24 cases	12 oz bottles-22 cases 12 oz cans-32 cases	12 oz bottles-37.5 cases 12 oz cans-55 cases
Number of Lids	1	2		3
Casters	None			
Power	124 W			186 W
Current	2 A	2.3 A	2.6 A	4.2 A
Electrical	110 - 120V / 60Hz / 1Ph			
Temperature Controller	Mechanical/ Temperature Range 7 to 1 (coldest to warmest)			
Temperature Range	0.5-3.3°C (33-38°F)			
Refrigerant	R290			
Insulation Material	Cyclopentane			
Cooling System	Ventilated			
Defrosting	Automatic			
Interior Dimensions (WDH)	22.3" x 23" x 15.7" / 566 x 583 x 400 mm	45" x 23" x 26" / 1143 x 584 x 660 mm	60" x 23" x 26" / 1524 x 584 x 600.4 mm	23" x 91.1" x 26.1" / 583 x 2314 x 662 mm
Net Weight	127.9 lbs/ 58 kgs	180.8 lbs/ 82 kgs	253.5 lbs/ 115 kgs	341.7 lbs/ 155 kgs
Net Dimensions (WDH)	28.1" x 26.4" x 34.2" / 713 x 670 x 869 mm	49.5" x 28" x 34.2" / 1257 x 712 x 869 mm	64.5" x 28" x 34.2" / 1638 x 713 x 869 mm	28.1" x 95.2" x 34.2" / 713 x 2418 x 869 mm
Gross Weight	176.4 lbs/ 80 kgs	247 lbs/ 112 kgs	330.7 lbs/ 150 kgs	366 lbs/ 166 kgs
Gross Dimensions (WDH)	32.7" x 32.7" x 41.7" / 830 x 830 x 1060 mm	56" x 33" x 42" / 1422 x 832 x 1061 mm	70" x 33" x 42" / 1778 x 832 x 1061 mm	101" x 32" x 42" / 2565 x 813 x 1067 mm
Plug Type	NEMA 5-15P			

** This equipment is intended for indoor environment using where ambient temperature do not exceed 26°C(80°F) & 55% relative humidity*



Stainless steel gliding lid



Lock



Built-in bottle opener



Aluminium coated interior

TECHNICAL DRAWING (measurements are in inches/mm)

Item: 50038- 26" wide

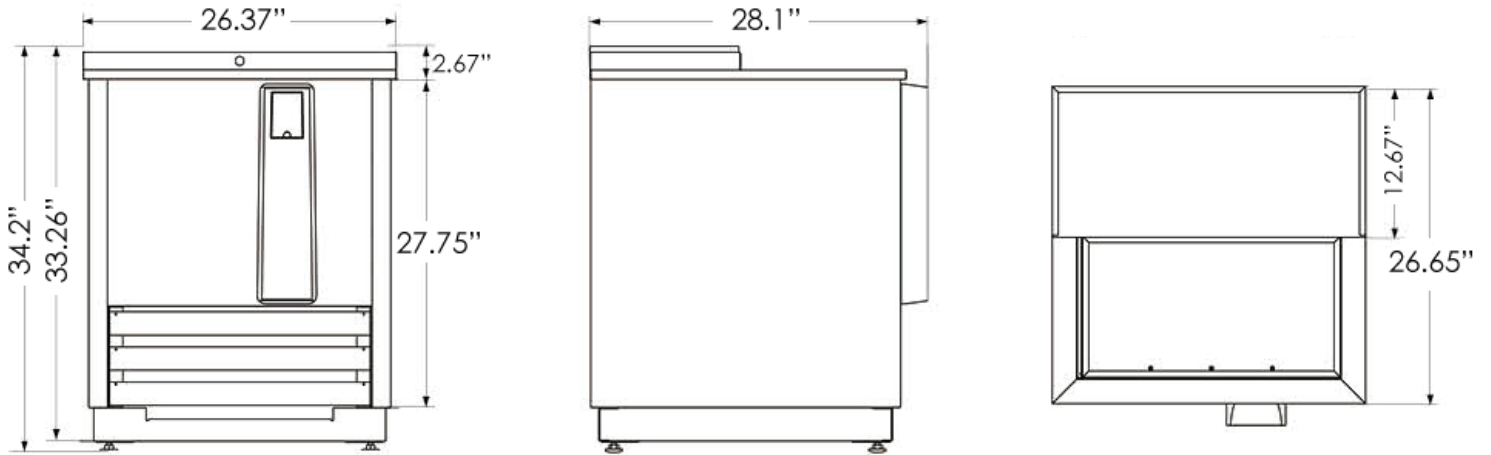

Item: 50039- 50" wide

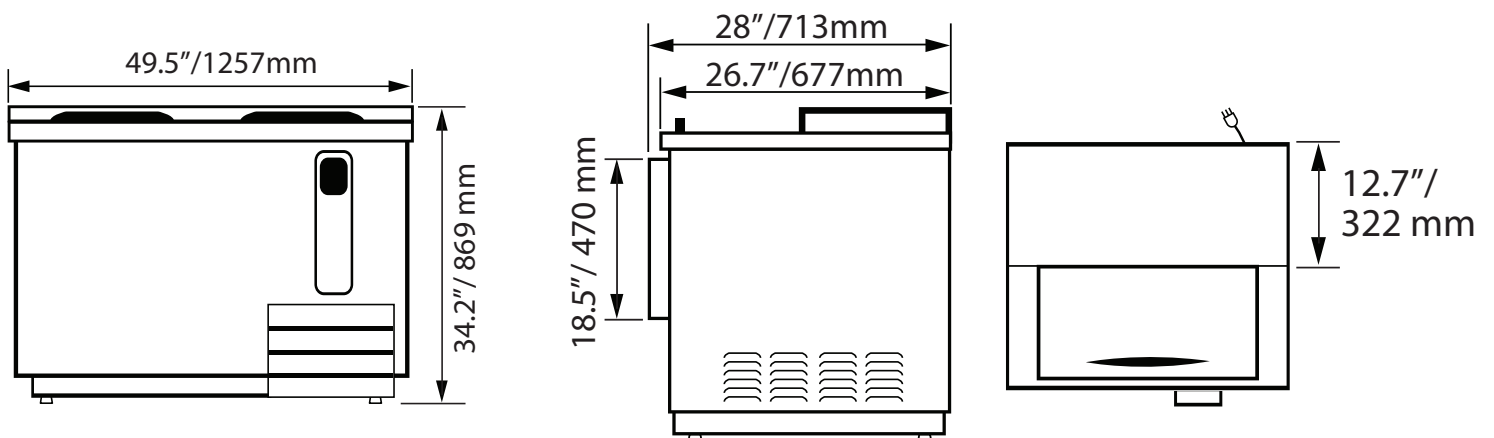

TECHNICAL DRAWING

Item: 50040- 65" wide

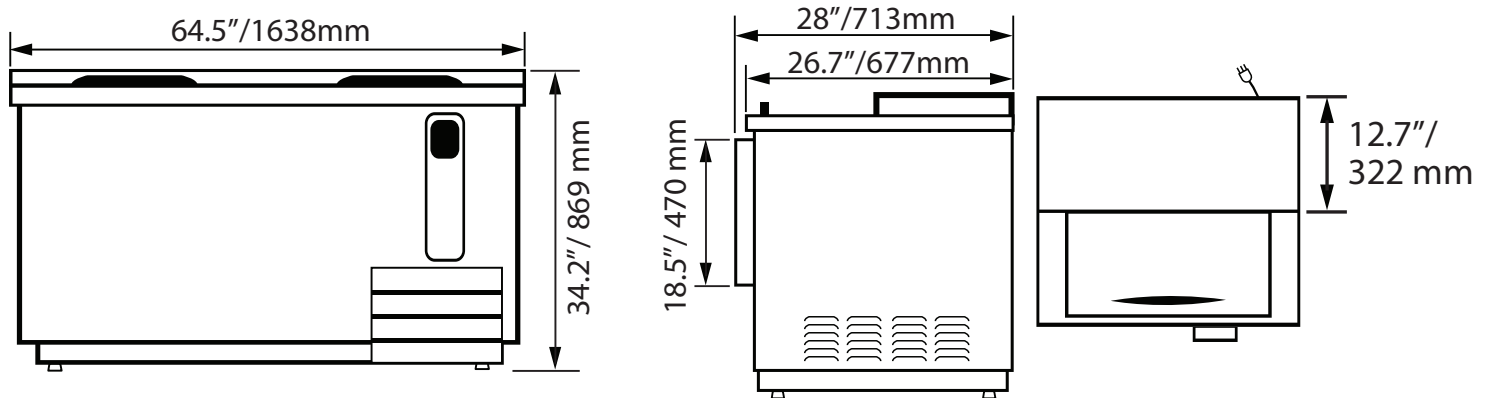

Item: 50041- 95" wide

