



Waffle Maker

Model CE-CN-0190

Item 40304

Instruction Manual



Revised - 11/05/2025

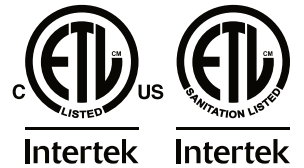

Toll Free: 1-800-465-0234
Fax: 905-607-0234
Email: service@omcan.com
www.omcan.com



Table of Contents

Model CE-CN-0190

Section	Page
General Information -----	3 - 4
Safety and Warranty -----	4 - 6
Technical Specifications -----	6
Installation -----	6
Operation -----	7
Maintenance -----	7 - 8
Parts Breakdown -----	9 - 10
Electrical Schematics -----	11
Notes -----	12 - 14
Warranty Registration -----	15



General Information

Omcan Manufacturing and Distributing Company Inc., Food Machinery of America, Inc. dba Omcan and Omcan Inc. are not responsible for any harm or injury caused due to any person's improper or negligent use of this equipment. The product shall only be operated by someone over the age of 18, of sound mind, and not under the influence of any drugs or alcohol, who has been trained in the correct operation of this machine, and is wearing authorized, proper safety clothing. Any modification to the machine voids any warranty, and may cause harm to individuals using the machine or in the vicinity of the machine while in operation.

CHECK PACKAGE UPON ARRIVAL

Upon receipt of an Omcan shipment please inspect for external damage. If no damage is evident on the external packaging, open carton to ensure all ordered items are within the box, and there is no concealed damage to the machine. If the package has suffered rough handling, bumps or damage (visible or concealed), please note it on the bill of lading before accepting the delivery and contact Omcan within 24 hours, so we may initiate a claim with the carrier. A detailed report on the extent of the damage caused to the machine must be filled out within three days, from the delivery date shown in the shipping documents. Omcan has no recourse for damaged products that were shipped collect or third party.

Before operating any equipment, always read and familiarize yourself with all operation and safety instructions.

Omcan would like to thank you for purchasing this machine. It's of the utmost importance to save these instructions for future reference. Also save the original box and packaging for shipping the equipment if servicing or returning of the machine is required.

Omcan Fabrication et distribution Compagnie Limitée et Food Machinery d'Amérique, dba Omcan et Omcan Inc. ne sont pas responsables de tout dommage ou blessure causé du fait que toute personne ait utilisé cet équipement de façon irrégulière. Le produit ne doit être exploité que par quelqu'un de plus de 18 ans, saine d'esprit, et pas sous l'influence d'une drogue ou d'alcool, qui a été formé pour utiliser cette machine correctement, et est vêtu de vêtements de sécurité appropriés. Toute modification de la machine annule toute garantie, et peut causer un préjudice à des personnes utilisant la machine ou des personnes à proximité de la machine pendant son fonctionnement.

VÉRIFIEZ LE COLIS DÈS RÉCEPTION

Dès réception d'une expédition d'Omcan veuillez inspecter pour dommages externes. Si aucun dommage n'est visible sur l'emballage externe, ouvrez le carton afin de s'assurer que tous les éléments commandés sont dans la boîte, et il n'y a aucun dommage dissimulé à la machine. Si le colis n'a subi aucune mauvaises manipulations, de bosses ou de dommages (visible ou cachée), notez-le sur le bond de livraison avant d'accepter la livraison et contactez Omcan dans les 24 heures qui suivent, pour que nous puissions engager une réclamation auprès du transporteur. Un rapport détaillé sur l'étendue des dommages causés à la machine doit être rempli dans un délai de trois jours, à compter de la date de livraison indiquée dans les documents d'expédition. Omcan n'a aucun droit de recours pour les produits endommagés qui ont été expédiés ou cueillis par un tiers transporteur.

Avant d'utiliser n'importe quel équipement, toujours lire et vous familiariser avec toutes les opérations et les

General Information

consignes de sécurité.

Omcan voudrais vous remercier d'avoir choisi cette machine. Il est primordial de conserver ces instructions pour une référence ultérieure. Également conservez la boîte originale et l'emballage pour l'expédition de l'équipement si l'entretien ou le retour de la machine est nécessaire.

Omcan Empresa De Fabricacion Y Distribucion Inc. Y Maquinaria De Alimentos De America, Inc. dba Omcan y Omcan Inc. no son responsables de ningun daño o perjuicio causado por cualquier persona inadecuada o el uso descuidado de este equipo. El producto solo podra ser operado por una persona mayor de 18 años, en su sano juicio y no bajo alguna influencia de droga o alcohol, y que este ha sido entrenado en el correcto funcionamiento de esta máquina, y ésta usando ropa apropiada y autorizada. Cualquier modificación a la máquina anula la garantía y puede causar daños a las personas usando la máquina mientras esta en el funcionamiento.

REVISE EL PAQUETE A SU LLEGADA

Tras la recepcion de un envio Omcan favor inspeccionar daños externos. Si no hay daños evidentes en el empaque exterior, Habra el carton para asegurarse que todos los articulos solicitados estén dentro de la caja y no encuentre daños ocultos en la máquina. Si el paquete ha sufrido un manejo de poco cuidado, golpes o daños (visible o oculto) por favor anote en la factura antes de aceptar la entrega y contacte Omcan dentro de las 24 horas, de modo que podamos iniciar una reclamación con la compañía. Un informe detallado sobre los daños causados a la máquina debe ser llenado en el plazo de tres días, desde la fecha de entrega que se muestra en los documentos de envío. Omcan no tiene ningun recurso por productos dañados que se enviaron a recoger por terceros.

Antes de utilizar cualquier equipo, siempre lea y familiarizarse con todas las instrucciones de funcionamiento y seguridad.

Omcan le gustaría darle las gracias por la compra de esta máquina. Es de la mayor importancia para salvar estas instrucciones para futuras consultas. Además, guarda la caja original y el embalaje para el envío del equipo si servicio técnico o devolución de la máquina que se requiere.

Safety and Warranty

Warning: improper installation, adjustment, alteration, service or maintenance can cause property damage, injury or death. Read the installation, operation and maintenance instructions thoroughly before installing or servicing this appliance.

FOR YOUR SAFETY

Do not store gasoline or other flammable liquids in the vicinity of this or any other appliance.



Safety and Warranty

WARNING: FIRE HAZARD

The area where the appliance is installed must be kept clear of combustibles and flammables. This includes mops, rags, grease, wrapping paper and electrical cords.

WARNING: ELECTRICAL GROUNDING INSTRUCTIONS

This appliance is equipped with a three-prong (grounding) plug for your protection against shock hazard and should be plugged directly into a properly grounded three-prong receptacle. Do not cut or remove the grounding prong from this plug.

NOTICE

This appliance is designed for use in non-combustible locations only. Install the appliance on a firm, level, non-combustible surface. For servicing, a clearance of 6 inches (15cm) from rear of the appliance to wall should be kept.

The equipment adopts contacted switch and LED digital panel. The equipment can be set the heating temperature and heating time. It can alarm automatically when it reaches the setting time. The tray can be wound around the shaft 180°clockwise or anticlockwise, easy to operate. The two head have two independent circuit diagrams, and can be used independently.

IMPORTANT: DO NOT DISCARD THIS MANUAL

This manual is considered to be part of the appliance and is to be given to the owner or manager of the hotel or restaurant, or to the person responsible for training operators of this appliance. It should be retained for future reference. Additional manuals are available from your local dealer.

RESIDENTIAL USERS: vendor assumes no liability for parts or labor coverage for component failure or other damages resulting from installation in non-commercial or residential applications. The right is reserved to deny shipment for residential usage; if this occurs, you will be notified as soon as possible.

1 YEAR PARTS AND LABOUR WARRANTY

Within the warranty period, contact Omcan Inc. at 1-800-465-0234 to schedule an Omcan authorized service technician to repair the equipment locally.

Unauthorized maintenance will void the warranty. Warranty covers electrical and part failures, not improper use.

Please see <https://omcan.com/disclaimer> for complete info.

WARNING:

The packaging components are classified as normal solid urban waste and can therefore be disposed of without difficulty.

In any case, for suitable recycling, we suggest disposing of the products separately (differentiated waste)

Safety and Warranty

according to the current norms.

DO NOT DISCARD ANY PACKAGING MATERIALS IN THE ENVIRONMENT!

Technical Specifications

Model	IC-CN-0350-D
Item Number	48349
Max Temperature	229.4°C / 445°F
Power	1100 W
Electrical	110 - 120V / 60Hz / 1
Output per Hour	20 Belgian Waffles
Plate Size (Dia.)	7.5" / 191mm
Net Dimensions	9.8" x 15" x 11.8" / 250 x 380 x 300mm
Net Weight	22 lbs. / 10 kgs.
Packaging Weight	24 lbs. / 10.9 kgs.

Installation

- The voltage must be coordinated with the supply voltage as indicated.
- Install a protection device before the socket, and make sure the connection is grounded.
- Place the equipment on a stable working table. Ensure the equipment is far away from flammable substances.
- Don't touch the tray, lid or handle when in operation in case of scald.
- Use a damp towel with mild detergent to clean the equipment. Don't clean it with a water jet. Don't submerge the equipment into water, otherwise, it will damage the control panel and other accessories, and cause a dangerous fault.
- The function of the time setting only alarms the operation time, the equipment won't turn off. So the operator should always be attentive.
- The power cord must not come into contact with any hot part or locations.
- Do not operate during a thunderstorm, unplug the plug and stop using the appliance at once.

1. When the power on, the buzzer will beep three times. At the same time, the LED will show the previous set time. Then, it will be in this setting time state. If you press the "START/STOP" key, the time will countdown to zero according to the appeared time. When it reaches the set time, the buzzer will beep three times again. If you press the "START/STOP" key again, the alarm will stop and show the preset time.
2. Time setting: if the list is on temperature setting list, press the "SET" key, and it will turn to the time setting list. During setting the time, first, press the "+" (or "-") key, then press the "START/STOP" key, you can set the time. During setting the time, don't release the "+" (or "-") key. If you press the "START/STOP" key one time, the time will increase (or reduce) by one second. If you press the "START/STOP" key continuously, the time will increase (or decrease) very fast. The time range is from 00:00" to 99:59". Please note: If you press the "START/STOP" key only or press the "START/STOP" key first, the list will count down to zero automatically.
3. Temperature setting: if the list is on time setting list, first press the "SET" key, at the same time, press the "START/STOP" key one time, then it will turn to the temperature setting list. If you press the "+" (or "-") key one time, the temperature will increase (or decrease) by one degree. The temperature range is from 124°C to 230°C (255.2°F~446°F). When the setting temperature is higher than the temperature the probe can measure, it will connect to the electric element automatically. It will stop heating when it reaches the setting degree.
4. Time counting: press the "START/STOP" key when the list is on time setting, and the time will countdown to zero according to the appeared time. When it reaches the setting time, the buzzer will beep three times. If you press the "START/STOP" key again, the alarm will stop and show the preset time.
5. The panel can store the previous setting time and temperature. If the probe was damaged in operation, the electric element will stop heating, and will show "Err" in the panel.
6. According the above instructions, the operator can set the time and temperature according to different requirements. Pour the batter on the bottom tray, then close the trays, and press the "START/STOP" key. When it reaches the set time, the buzzer will sound, and the operator should remove the food out of the tray. If the operator does not remove them on time, the food will burn.

Note: the longer the time, and the higher the temperature, the darker the color. If the cooking time is too short, the food will not be cooked and its color will be lighter.

Maintenance

CLEANING

THIS APPLIANCE SHOULD NOT BE CLEANED WITH A WATER JET OR IMMERSSED IN WATER. USE ONLY A DAMP CLOTH OR SPONGE DIPPED IN SOAPY WATER. DO NOT USE STEEL-WOOL WHICH WILL DAMAGE THE BRIGHT STAINLESS STEEL FINISH.

1. Always ensure that the appliance is disconnected from the main power supply before cleaning.
2. This appliance should not be cleaned with a water jet or immersed in water. Use only a damp cloth or sponge dipped in soapy water. Failure to observe this instruction will invalidate the warranty.
3. Wipe off the appliance with a dry cloth and wait at least half an hour before re-connecting to the main

Maintenance

power outlet.

4. The plates are Teflon coated and should only be cleaned with a damp cloth. Under no circumstances should the plates be cleaned with abrasive wool as this will invalidate the warranty.

Parts Breakdown

Model CE-CN-0190 40304

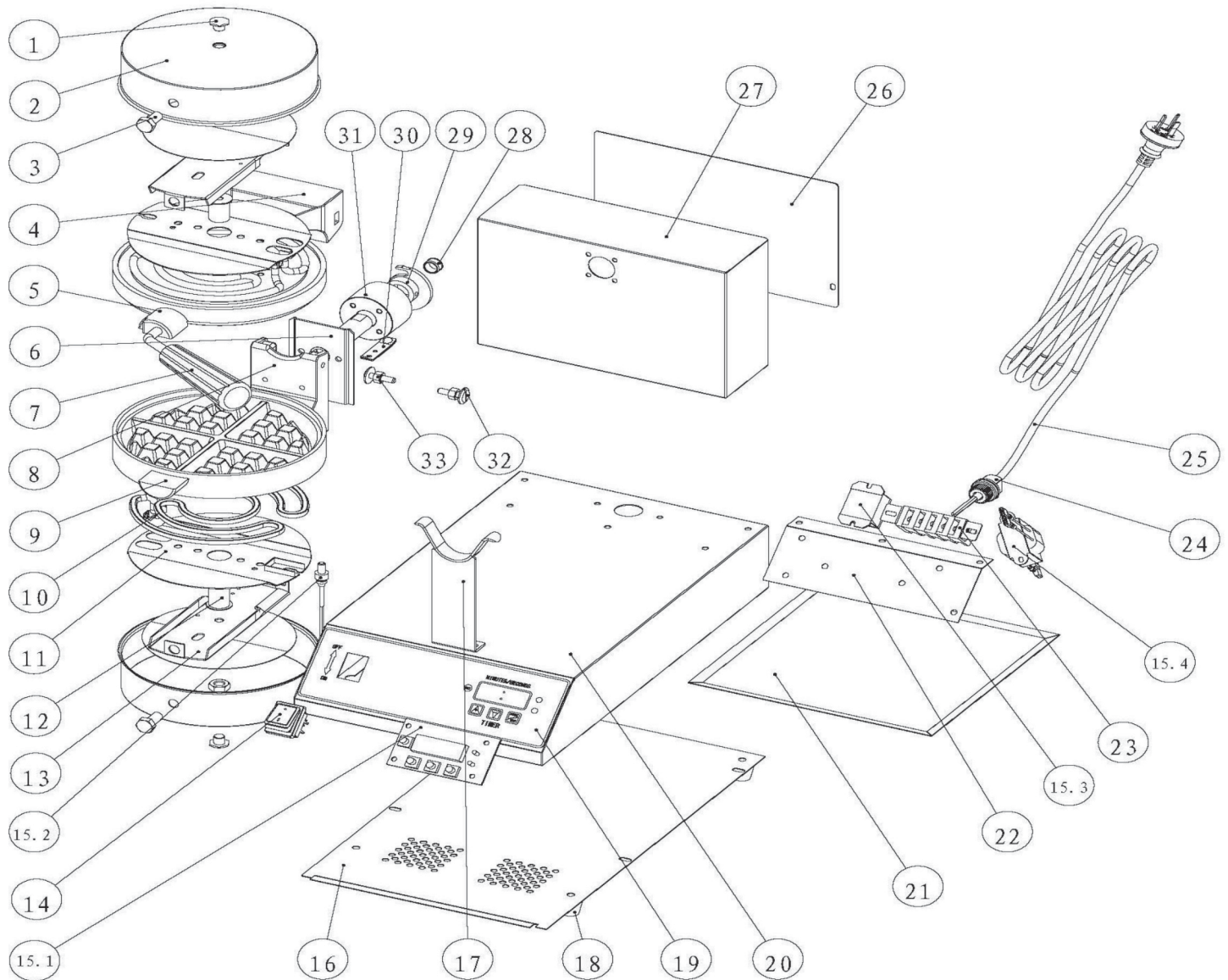

Parts Breakdown

Model CE-CN-0190 40304

Item No.	Description	Position	Item No.	Description	Position	Item No.	Description	Position
AW481	HEAD SCREW FOR 40304	1	AW488	PRESSER BIT FOR HEATING ELEMENTS FOR 40304	11	AW494	POWER CORD FOR 40304	25
AW482	TOP COVER PLATE FOR 40304	2	AW489	CROSS BEAM FOR 40304	13	AW495	ROTATING JACKET FOR 40304	28
AW483	UPPER ROTATING SHAFT FOR 40304	4	AD712	POWER SWITCH FOR 40304	14	AW496	BASE HOLDER FOR 40304	29
AW484	UPPER BAKING PAN FOR 40304	5	AW490	COMPLETE DIGITAL BOARD 120V FOR 40304	15	AW497	LEAF SPRING FOR 40304	30
AW362	PRESS SCREEN HANDLE FOR 40304	7	AW491	FOOT FOR 40304	18	AW498	ALUMINUM BASE FOR 40304	31
AW485	LOWER ROTATING SHAFT FOR 40304	8	AW492	FACIAL PANEL FOR 40304	19	AW499	SCREW FOR 40304	32
AW486	LOWER BAKING PAN FOR 40304	9	AW493	TERMINAL BLOCK FOR 40304	23	AW500	NUT FOR 40304	33
AW487	HEATING ELEMENTS FOR 40304	10	AJ591	POWER CORD SHEATH FOR 40304	24			

Electrical Schematics

Model CE-CN-0190 40304

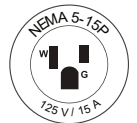
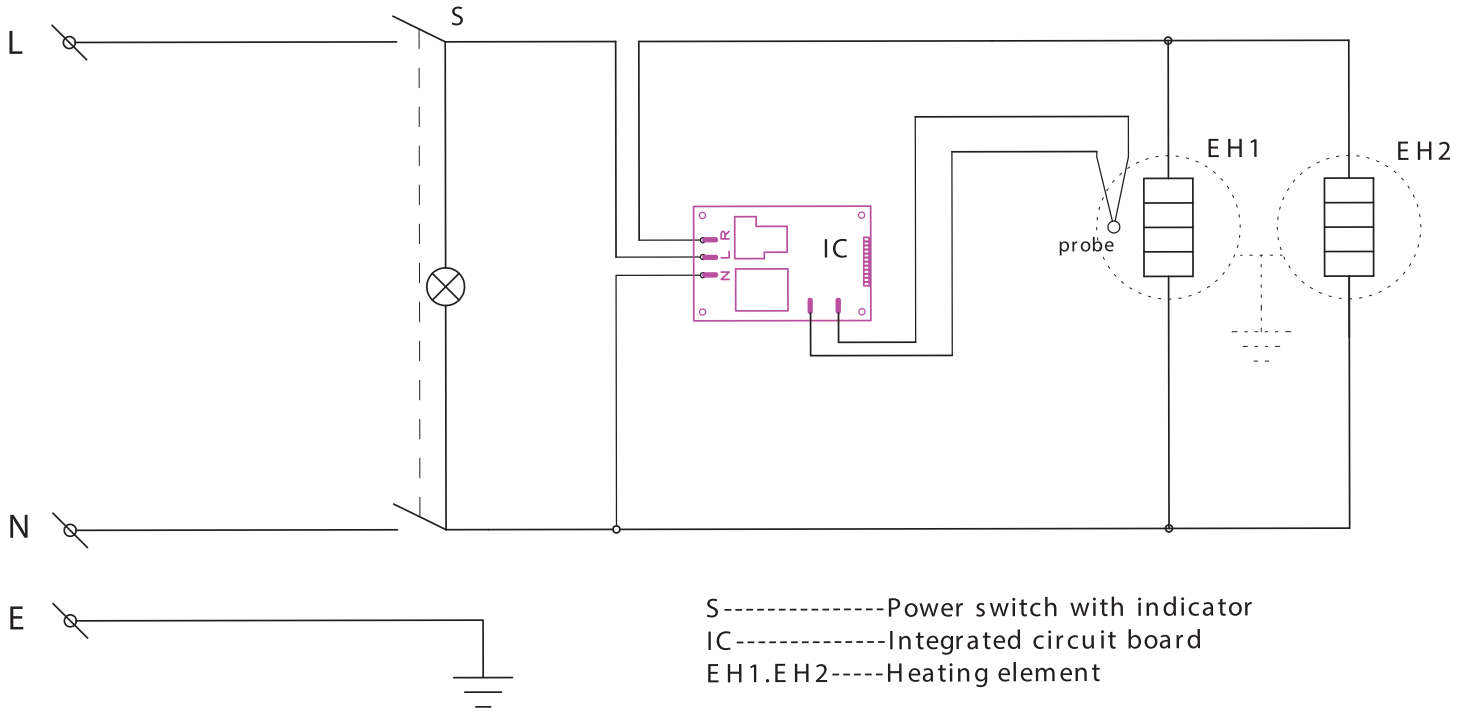



Warranty Registration

Thank you for purchasing an Omcan product. To register your warranty for this product, complete the information below, tear off the card at the perforation and then send to the address specified below. You can also register online by visiting:

Merci d'avoir acheté un produit Omcan. Pour enregistrer votre garantie pour ce produit, complétez les informations ci-dessous, détachez la carte au niveau de la perforation, puis l'envoyer à l'adresse spécifiée ci-dessous. Vous pouvez également vous inscrire en ligne en visitant:

Gracias por comprar un producto Omcan usted. Para registrar su garantía para este producto, complete la información a continuación, cortar la tarjeta en la perforación y luego enviarlo a la dirección indicada a continuación. También puede registrarse en línea en:

<https://omcan.com/warranty-registration/>

For mailing in Canada

Pour postale au Canada

Por correo en Canadá

For mailing in the US

Pour diffusion aux États-Unis

Por correo en los EE.UU.

OMCAN

PRODUCT WARRANTY REGISTRATION

3115 Pepper Mill Court,
Mississauga, Ontario
Canada, L5L 4X5

OMCAN

PRODUCT WARRANTY REGISTRATION

4450 Witmer Industrial Estates, Unit 4,
Niagara Falls, New York
USA, 14305

or email to: service@omcan.com



Purchaser's Information

Name: _____

Address: _____

City: _____ Province or State: _____ Postal or Zip: _____

Country: _____

Dealer from which Purchased: _____

Dealer City: _____ Dealer Province or State: _____

Invoice: _____

Model Name: _____ Model Number: _____

Machine Description: _____

Date of Purchase (MM/DD/YYYY): _____

Would you like to extend the warranty? Yes No

Company Name: _____

Telephone: _____

Email Address: _____

Type of Company:

Restaurant Bakery Deli

Butcher Supermarket Caterer

Institution (*specify*): _____

Other (*specify*): _____

Serial Number: _____

Date of Installation (MM/DD/YYYY): _____

Thank you for choosing Omcan | Merci d'avoir choisi Omcan | Gracias por elegir Omcan



Since 1951 Omcan has grown to become a leading distributor of equipment and supplies to the North American food service industry. Our success over these many years can be attributed to our commitment to strengthen and develop new and existing relationships with our valued customers and manufacturers. Today with partners in North America, Europe, Asia and South America, we continually work to improve and grow the company. We strive to offer customers exceptional value through our qualified local sales and service representatives who provide convenient access to over 6,500 globally sourced products.

Depuis 1951 Omcan a grandi pour devenir un des "leaders" de la distribution des équipements et matériel pour l'industrie des services alimentaires en Amérique du Nord. Notre succès au cours de ces nombreuses années peut être attribué à notre engagement à renforcer et à développer de nouvelles et existantes relations avec nos clients et les fabricants de valeur. Aujourd'hui avec des partenaires en Amérique du Nord, Europe, Asie et Amérique du Sud, nous travaillons continuellement à améliorer et développer l'entreprise. Nous nous efforçons d'offrir à nos clients une valeur exceptionnelle grâce à nos ventes locales qualifiées et des représentants de service qui offrent un accès facile à plus de 6500 produits provenant du monde entier.

Desde 1951 Omcan ha crecido hasta convertirse en un líder en la distribución de equipos y suministros de alimentos en América del Norte industria de servicios. Nuestro éxito en estos años se puede atribuir a nuestro compromiso de fortalecer y desarrollar nuevas relaciones existentes con nuestros valiosos clientes y fabricantes. Hoy con socios de América del Norte, Europa, Asia y América del Sur, que trabajan continuamente para mejorar y crecer la empresa. Nos esforzamos por ofrecer a nuestros clientes valor excepcional a través de nuestro local de ventas y representantes de los servicios que proporcionan un fácil acceso a más de 6,500 productos con origen a nivel mundial.

