



SERVING THE FOOD INDUSTRY SINCE 1951

36" Chrome Plated Heavy Duty Griddle

ITEM: 48597
MODEL: CE-CN-53303F



A Large Countertop Griddle with Durable Construction & Chromed Plate

A spectacular griddle both in appearance and in function, this piece of equipment ensures even cooking and fast temperature recovery. Durable metal knobs are comfortable to use and resistant to accidental damage.

- Brushed stainless steel housing
- Food grade chrome plating
- Max 300C temperature
- Even cooking temperature surface & quick recovery
- Front & rear grease grooves
- Adjustable feet

Telephone: 1-800-465-0234

Fax: (905) 607-0234

Email: sales@omcan.com

Website: www.omcan.com



Authorized Dealer



*Power cord and plug not included; must be installed by a certified electrician



TECHNICAL DRAWING

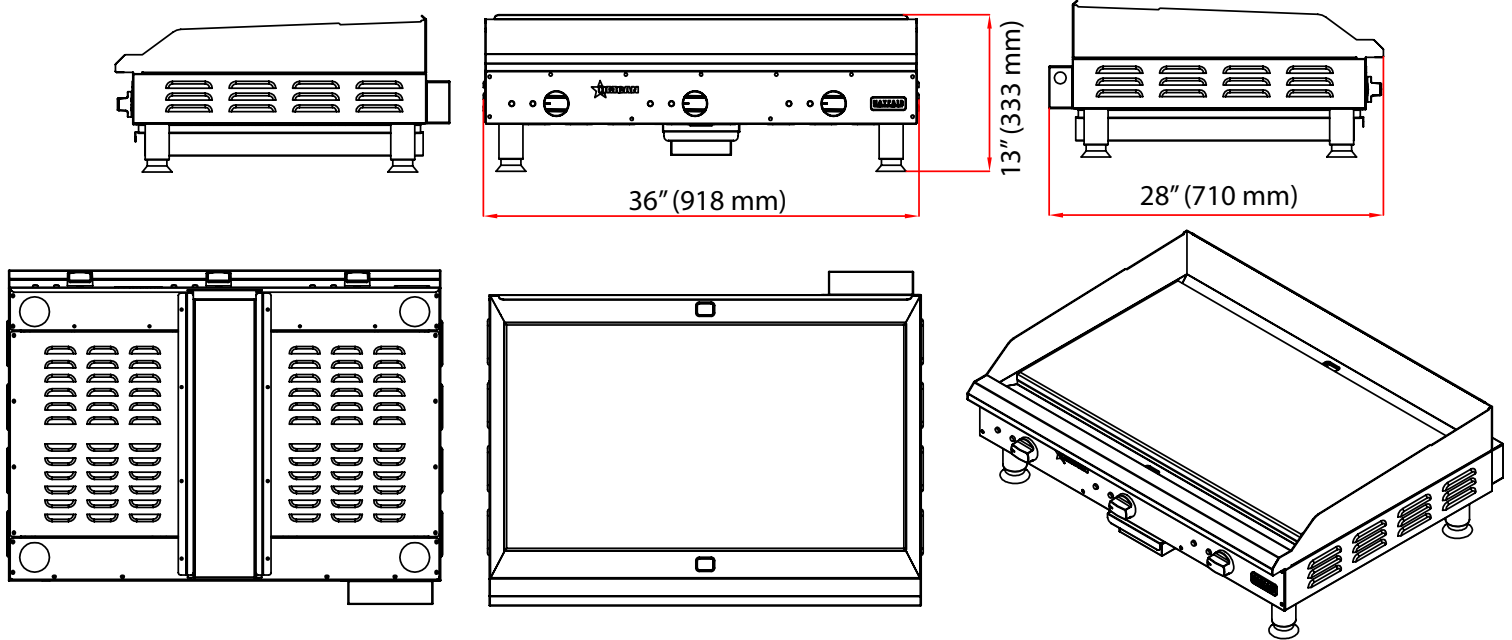

TECHNICAL SPECIFICATION

Item	48597
Model	CE-CN-53303F
Grill Surface	33.6" x 19" (855x 485 mm)
Power	10800 W
Electricals	240V / 60Hz / 1Ph
Net Dimensions	36" x 28" x 13" (918 x 710 x 333 mm)
Gross Dimensions	40.5" x 32.3" x 18.5" (1030 x 820 x 470 mm)
Net Weight	202.4 lb. (91.8 kg)
Gross Weight	235 lb. (106.5 kg)

*Dimensions rounded up to the nearest tenth inch or millimeter.
Specifications subject to change without notice.*