



SERVING THE FOOD INDUSTRY SINCE 1951

27" Black Countertop Refrigerated Display with 3.5cu.ft. / 100L capacity

ITEM: 27155

MODEL: RS-CN-0100-E

Display food attractively to drive impulse sales.



Showcase your refrigerated products with clarity and style using our glass display case. The four-sided glass design ensures customers get a full view from any angle, making it ideal for highlighting beverages, snacks, or desserts. With its generous capacity, this countertop unit is well-suited for high-traffic areas like convenience stores, cafés, or bakeries, and features rear sliding doors for easy access during busy service times.

Designed with a digital temperature controller and eco-friendly R290 refrigerant, this unit keeps your items at optimal temperatures while minimizing energy impact. Interior lighting enhances product visibility, drawing attention and fits neatly on tabletops. The unit includes two fixed shelves, with space for up to three, making it both compact and spacious for flexible merchandising.

FEATURES:

- Rear sliding doors for easy access
- Bright interior LED lighting
- Glass panels on all sides for full visibility
- Compact design fits standard countertops
- Comes with 2 fixed shelves
- Supports up to 3 shelves total

Telephone: 1-800-465-0234

Fax: (905) 607-0234

Email: sales@omcan.com

Website: www.omcan.com



Authorized Dealer



Made in China

(Version 2025.07)

Page 1 / 2

TECHNICAL DRAWING

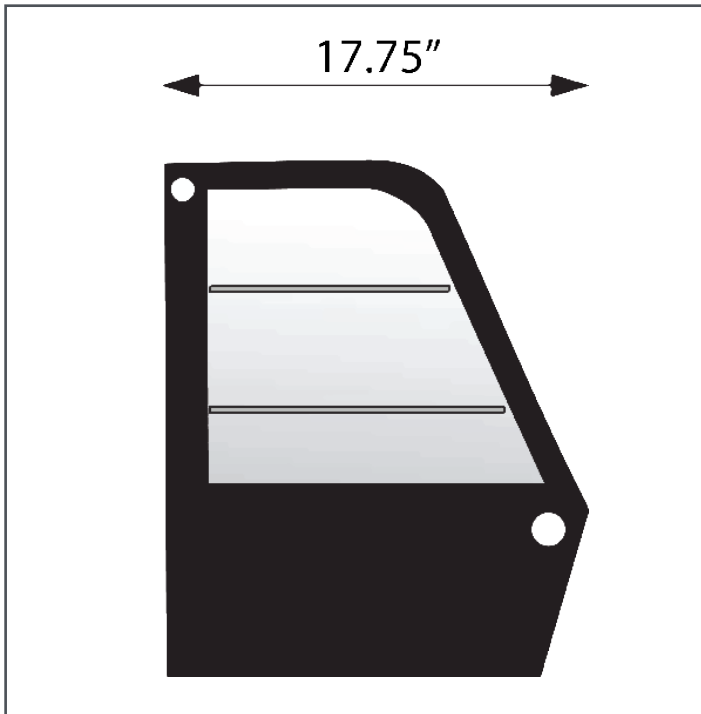
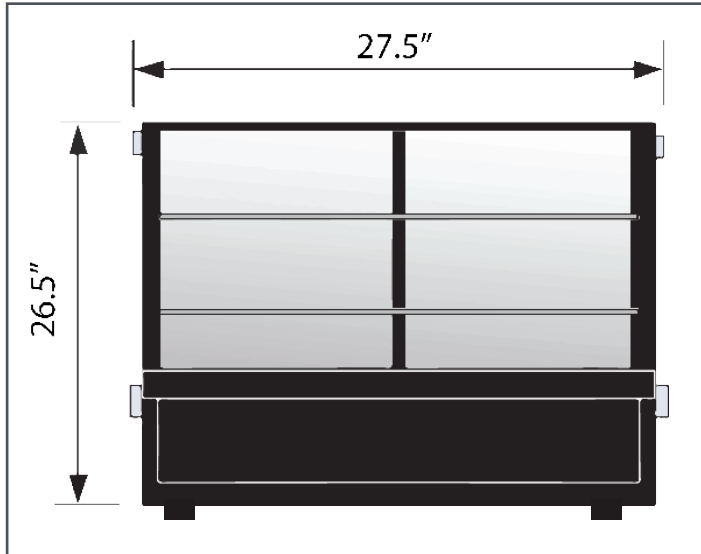

TECHNICAL SPECIFICATION

Item	27155
Model	RS-CN-0100-E
Capacity	3.5cu.ft. / 100L
Maximum Load	33 lbs/ 15 kgs
Number of Doors	2 Sliding Doors
Number of Shelves	2-3 Shelves
Shelf Dimensions	25" x 13" / 645 x 323 mm
Shelf Material	Chrome
Interior Material	Plastic
Exterior Material	Plastic + Metal
Power	170W
Lamp Power	3.2 W
Current	1.5A
Electrical	110V / 60Hz / 1Ph
Temperature Controller	Digital
Temperature Range	12° to 0°C / 54° to 32°F
Refrigerant	R290
Injection	40g
Plug Type	NEMA 5-15P
Type Of Climate	4
Defrosting	Automatic
Cooling System	Forced Air
Interior Dimensions (WDH)	26" x 13" x 16" / 654 x 327 x 397 mm
Net Weight	86 lbs / 39.1 kgs
Net Dimensions (WDH)	27" x 17.8" x 27" / 682 x 450 x 675 mm
Gross Weight	95 lbs / 43 kgs
Gross Dimensions (WDH)	30" x 20.6" x 30" / 756 x 524 x 760 mm