



Popcorn Machine

Model CE-CN-0227-R

Item 40385

Instruction Manual



Revised - 11/04/2025



Toll Free: 1-800-465-0234
Fax: 905-607-0234
Email: service@omcan.com
www.omcan.com



Table of Contents

Model CE-CN-0227-R

Section	Page
General Information -----	3 - 4
Safety and Warranty -----	4 - 6
Technical Specifications -----	6
Operation -----	6 - 7
Maintenance -----	7
Troubleshooting -----	7
Parts Breakdown -----	8 - 10
Electrical Schematics -----	11
Notes -----	12 - 14
Warranty Registration -----	15



General Information

Omcan Manufacturing and Distributing Company Inc., Food Machinery of America, Inc. dba Omcan and Omcan Inc. are not responsible for any harm or injury caused due to any person's improper or negligent use of this equipment. The product shall only be operated by someone over the age of 18, of sound mind, and not under the influence of any drugs or alcohol, who has been trained in the correct operation of this machine, and is wearing authorized, proper safety clothing. Any modification to the machine voids any warranty, and may cause harm to individuals using the machine or in the vicinity of the machine while in operation.

CHECK PACKAGE UPON ARRIVAL

Upon receipt of an Omcan shipment please inspect for external damage. If no damage is evident on the external packaging, open carton to ensure all ordered items are within the box, and there is no concealed damage to the machine. If the package has suffered rough handling, bumps or damage (visible or concealed), please note it on the bill of lading before accepting the delivery and contact Omcan within 24 hours, so we may initiate a claim with the carrier. A detailed report on the extent of the damage caused to the machine must be filled out within three days, from the delivery date shown in the shipping documents. Omcan has no recourse for damaged products that were shipped collect or third party.

Before operating any equipment, always read and familiarize yourself with all operation and safety instructions.

Omcan would like to thank you for purchasing this machine. It's of the utmost importance to save these instructions for future reference. Also save the original box and packaging for shipping the equipment if servicing or returning of the machine is required.

Omcan Fabrication et distribution Compagnie Limitée et Food Machinery d'Amérique, dba Omcan et Omcan Inc. ne sont pas responsables de tout dommage ou blessure causé du fait que toute personne ait utilisé cet équipement de façon irrégulière. Le produit ne doit être exploité que par quelqu'un de plus de 18 ans, saine d'esprit, et pas sous l'influence d'une drogue ou d'alcool, qui a été formé pour utiliser cette machine correctement, et est vêtu de vêtements de sécurité appropriés. Toute modification de la machine annule toute garantie, et peut causer un préjudice à des personnes utilisant la machine ou des personnes à proximité de la machine pendant son fonctionnement.

VÉRIFIEZ LE COLIS DÈS RÉCEPTION

Dès réception d'une expédition d'Omcan veuillez inspecter pour dommages externes. Si aucun dommage n'est visible sur l'emballage externe, ouvrez le carton afin de s'assurer que tous les éléments commandés sont dans la boîte, et il n'y a aucun dommage dissimulé à la machine. Si le colis n'a subi aucune mauvaises manipulations, de bosses ou de dommages (visible ou cachée), notez-le sur le bond de livraison avant d'accepter la livraison et contactez Omcan dans les 24 heures qui suivent, pour que nous puissions engager une réclamation auprès du transporteur. Un rapport détaillé sur l'étendue des dommages causés à la machine doit être rempli dans un délai de trois jours, à compter de la date de livraison indiquée dans les documents d'expédition. Omcan n'a aucun droit de recours pour les produits endommagés qui ont été expédiés ou cueilli par un tiers transporteur.

Avant d'utiliser n'importe quel équipement, toujours lire et vous familiariser avec toutes les opérations et les

General Information

consignes de sécurité.

Omcan voudrais vous remercier d'avoir choisi cette machine. Il est primordial de conserver ces instructions pour une référence ultérieure. Également conservez la boîte originale et l'emballage pour l'expédition de l'équipement si l'entretien ou le retour de la machine est nécessaire.

Omcan Empresa De Fabricacion Y Distribucion Inc. Y Maquinaria De Alimentos De America, Inc. dba Omcan y Omcan Inc. no son responsables de ningun daño o perjuicio causado por cualquier persona inadecuada o el uso descuidado de este equipo. El producto solo podra ser operado por una persona mayor de 18 años, en su sano juicio y no bajo alguna influencia de droga o alcohol, y que este ha sido entrenado en el correcto funcionamiento de esta máquina, y ésta usando ropa apropiada y autorizada. Cualquier modificación a la máquina anula la garantía y puede causar daños a las personas usando la máquina mientras esta en el funcionamiento.

REVISE EL PAQUETE A SU LLEGADA

Tras la recepcion de un envio Omcan favor inspeccionar daños externos. Si no hay daños evidentes en el empaque exterior, Habra el carton para asegurarse que todos los articulos solicitados estén dentro de la caja y no encuentre daños ocultos en la máquina. Si el paquete ha sufrido un manejo de poco cuidado, golpes o daños (visible o oculto) por favor anote en la factura antes de aceptar la entrega y contacte Omcan dentro de las 24 horas, de modo que podamos iniciar una reclamación con la compañía. Un informe detallado sobre los daños causados a la máquina debe ser llenado en el plazo de tres días, desde la fecha de entrega que se muestra en los documentos de envío. Omcan no tiene ningun recurso por productos dañados que se enviaron a recoger por terceros.

Antes de utilizar cualquier equipo, siempre lea y familiarizarse con todas las instrucciones de funcionamiento y seguridad.

Omcan le gustaría darle las gracias por la compra de esta máquina. Es de la mayor importancia para salvar estas instrucciones para futuras consultas. Además, guarda la caja original y el embalaje para el envío del equipo si servicio técnico o devolución de la máquina que se requiere.

Safety and Warranty

The unit is environment-friendly with an excellent design. It includes components to maximize power saving, complete functions and is easy to operate. The unit is easy to clean. Please review this manual prior to use and follow the cleaning instructions.

Operations and repairs of this product must be performed by the experts or qualified persons or those who have gotten the license of installation, or those who are authorized by the manufacturer.

- When conducting installation or maintenance, please follow these instructions carefully to ensure the safe

Safety and Warranty

use of this appliance.

- Please keep this instruction manual for future reference.
- Make sure none of the parts are missing or damaged upon arrival. If there is any doubt about the product, please do not use it, and contact Omcan at 1-800-465-0234.
- Keep the packing material out of reach of the children to avoid accident.
- This appliance could be only operated by the person who is familiar with the unit.
- When not using the appliance or the operator is absent, please turn off the unit to avoid any accidental injury or damage.
- The unit can only be repaired by trained personnel and only use original parts. It will be dangerous if not following the above requirements.
- Do not rinse the equipment with water directly.
- Clean the surface of stainless steel periodically with appropriate method to prevent any damage brought by oxidization or any other chemical interference.

IMPORTANT SAFEGUARDS

1. The machine should be put on a stable, level and firm surface. Avoid direct contact with sunlight or rain. Do not place on or near a hot gas or electric burner. Do not use outdoors.
2. Machine needs to be plugged into 110-120V dedicated circuit to operate properly. When using an electrical appliance, basic safety precautions should always be followed.
3. Always attach the plug to the appliance first, then plug the cord in the wall outlet. To disconnect, turn any control "off" then remove the plug from wall outlet.
4. Unplug the power cord from the outlet when not in use and before cleaning.

WARNING

1. Water must NEVER be put on the popping kettle.
2. DO NOT touch inside parts when the machine is hot as it may cause serious injury.

RESIDENTIAL USERS: Vendor assumes no liability for parts or labor coverage for component failure or other damages resulting from installation in non-commercial or residential applications. The right is reserved to deny shipment for residential usage; if this occurs, you will be notified as soon as possible.

1 YEAR PART AND LABOUR BENCH WARRANTY

Within the warranty period, contact Omcan Inc. at 1-800-465-0234 to schedule a drop off to either an Omcan authorized service depot in the area, or to an Omcan Service warehouse to repair the equipment.

Unauthorized maintenance will void the warranty. Warranty covers electrical and part failures, not improper use.

Please see <https://omcan.com/disclaimer> for complete info.

The packaging components are classified as normal solid urban waste and can therefore be disposed of without difficulty.

Safety and Warranty

For suitable recycling, we suggest disposing of the products separately (differentiated waste) according to local standards.

DO NOT DISCARD ANY PACKAGING MATERIALS IN THE ENVIRONMENT!

Technical Specifications

Item Number	40385
Model	CE-CN-0227
Temperature Range	220 - 260°C / 428 - 500°F
Power	1.3 kW
Efficiency	3-5 mins. per tray
Kettle Volume	8 oz. / 1 cup
Bowl Dimensions (Dia. x H)	8" x 2.8" / 203 x 70mm
Electrical	110-120V / 60Hz / 1
Weight	51.7 lbs. / 23.5 kgs.
Packaging Weight	90 lbs. / 40.8 kgs.
Inner Dimensions	13.3" x 18" x 20" / 337 x 457 x 508mm
Dimensions	16.5" x 22" x 29" / 419 x 559 x 737mm
Packaging Dimensions	47" x 36" x 41" / 1194 x 914 x 1041mm

Operation

TRANSPORTATION AND STORAGE

The unit should be handled with care to avoid damage to the glass. The unit should not be transported sideways or shook. The unit should not be placed in an outdoor area. It should be put in storage which has good ventilation and has no corrosive gases present. If must be put in outdoor area, do not let the unit be in contact with direct sunshine and rain.

OPERATING INSTRUCTIONS

1. Plug in the machine, turn on the power switch to start the heat tube and light.
2. Turn on the kettle switch to preheat the kettle for 5 to 6 minutes. Pour 50ml of oil, 150g of corn and 50g of sugar into the kettle, the corn will burst open.
3. Pay attention to the corn while popping in case it will be burnt. Close the door firmly so that the corn can

Operation

not flow out. Stir the corn until it is all burst open, then twist the handle clockwise, lift the elastic cover to the top. Keep the kettle hung upright and pour all the popcorn out from the plate.

- Repeat steps 1 - 3 to make more popcorn. It will only take 2 minutes to pop the corn in a continuous fashion.

Take care when pouring the oil to prevent scalding. Do not drop any oil around the plate. Otherwise it will catch fire when it is heated to a certain temperature. Keep the kettle clean.

This machine has over-temperature protection when the temperature rises over the normal line, it will cut off the electricity to protect the machine and the user.

Maintenance

- Clean your popcorn machine after every use.
- Make sure the machine is unplugged and the kettle has completely cooled.
- Wipe all oils off the inside and outside of the kettle with a DRY clean soft cloth.
- Do not use benzene, scrubbing brushes or chemical cleaners, as these will damage the machine.
- NEVER immerse the base of machine in water or let water drip inside.

Troubleshooting

Problem	Cause	Solutions
Lights are off while turned on.	The power cord is not properly plugged into the outlet or the machine.	Turn off all switches and make sure the power cord is firmly plugged into the outlet and machine. Turn on the switch again.
The motor does not rotate/heat when the TURN switch is on.	The heating tube line is loose/burnt.	Tighten the line/change the heating tube.
The heating temperature is too high or too low.	The constant temperature element is out of order.	Change the element.

Parts Breakdown

Model **CE-CN-0227-R** 40385

Machine

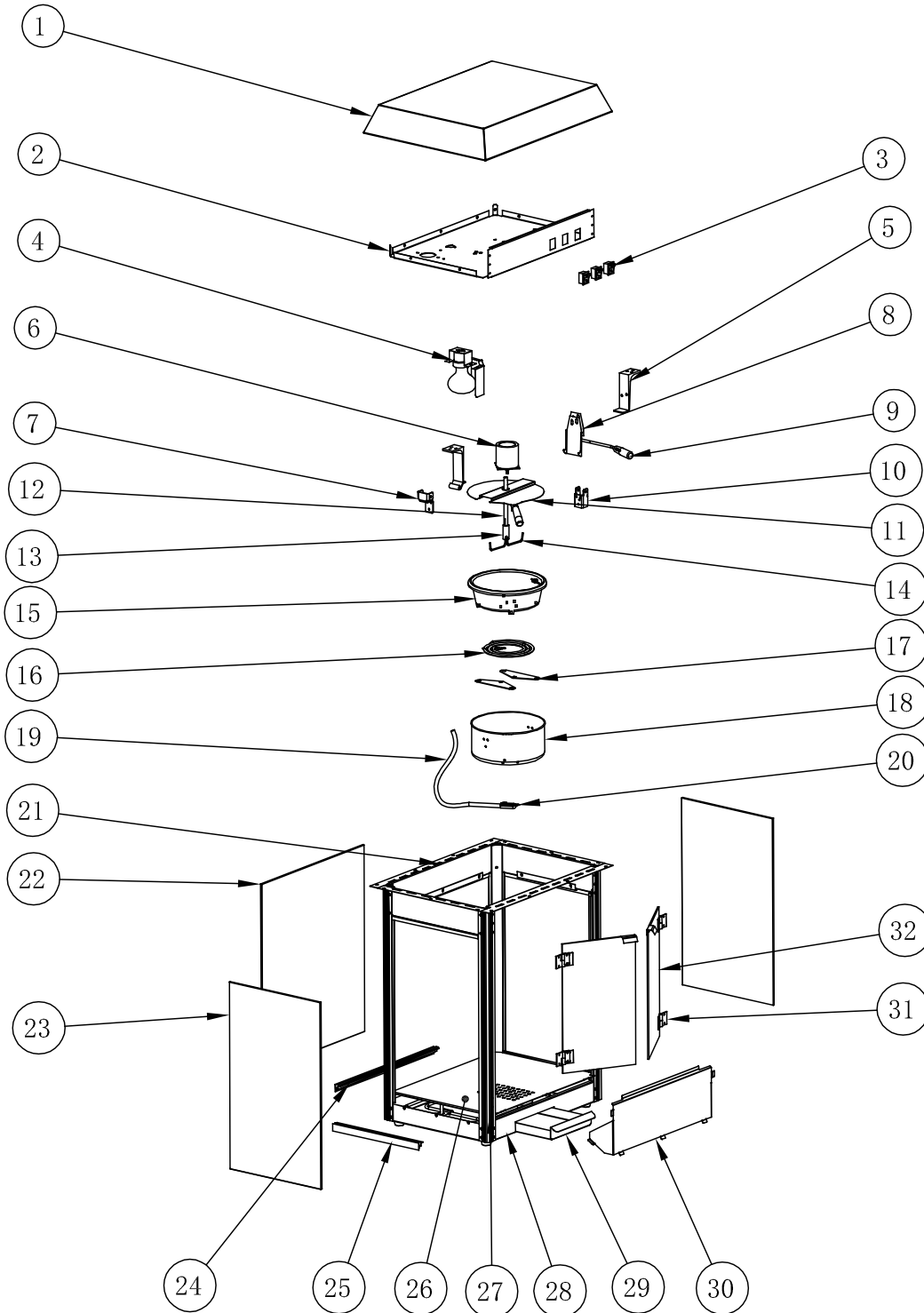

Parts Breakdown

Model **CE-CN-0227-R** 40385

Trolley

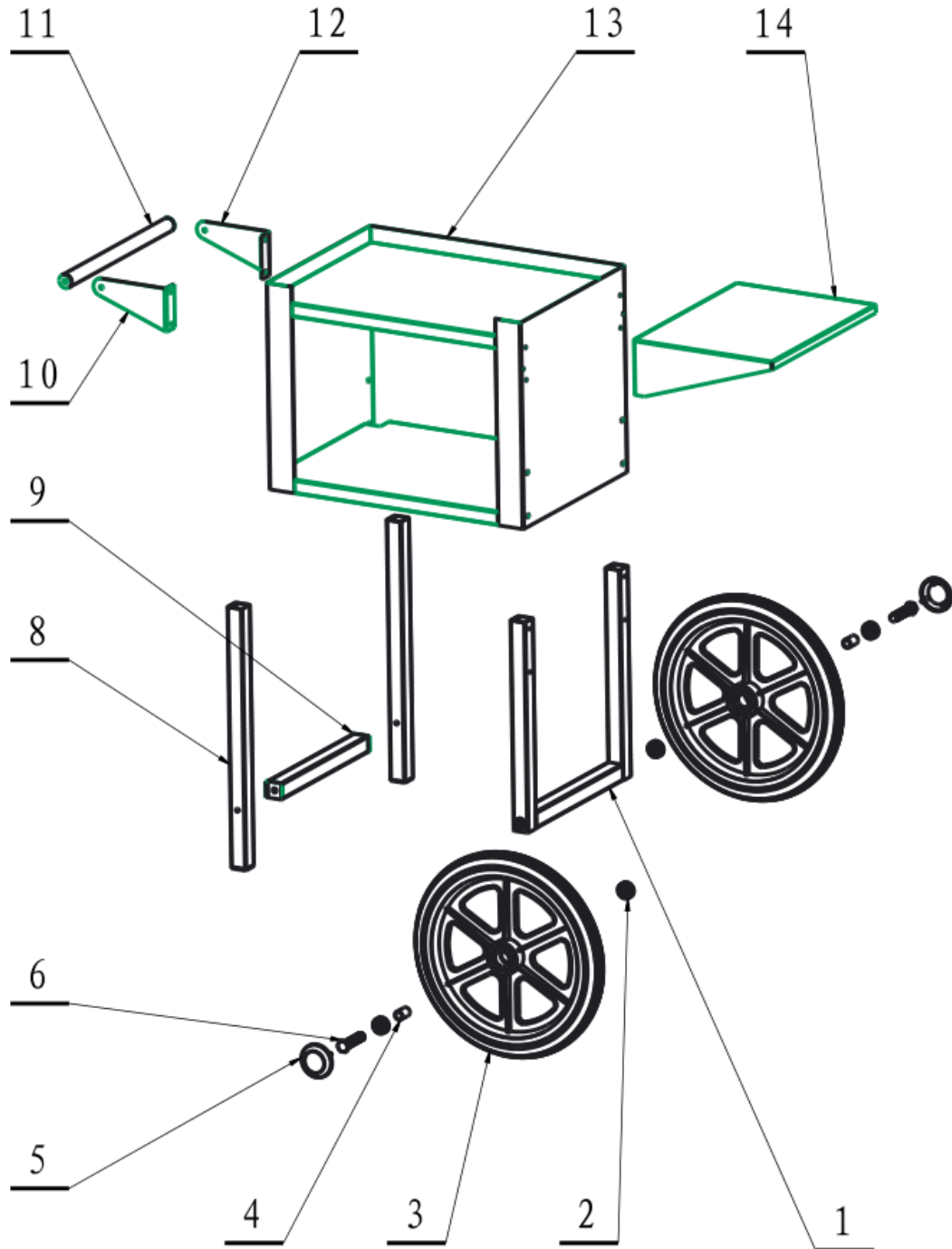

Parts Breakdown

Model CE-CN-0227-R 40385

Machine

Item No.	Description	Position	Item No.	Description	Position	Item No.	Description	Position
79107	HOOD FOR 40385	1	79118	STIRRER ARM FOR 40385	12	79130	BLACK GLASS SLOT FOR 40385	24
79108	UPPER PLATE FOR 40385	2	79119	STIRRER ARM ASSEMBLY FOR 40385	13	79131	LEFT-RIGHT GLASS SLOT FOR 40385	25
79109	SWITCH FOR 40385	3	79120	STIRRER POLE FOR 40385	14	79132	BOTTOM PLATE FOR 40385	26
79110	BULB SOCKET ASSEMBLY FOR 40385	4	79121	ALUMINUM TRAY FOR 40385	15	79133	CORNER ALUMINUM FOR 40385	27
67634	110-130V 60W LIGHT BULB FOR 40385	4	79122	HEATING PIPE FOR 40385	16	79134	BOTTOM BASE FOR 40385	28
79111	KETTLE RIGHT / LEFT HINGE ASSEMBLY FOR 40385	5	79123	COVER PLATE FOR HEATING PIPE FOR 40385	17	79135	KERNEL TRAY FOR 40385	29
79112	MOTOR FOR 40385	6	79124	OUT KETTLE SHELL FOR 40385	18	79136	PLATE UNDER THE FRONT DOOR FOR 40385	30
79113	HINGE LOCK FOR 40385	7	79125	METAL PIPE FOR 40385	19	79137	TOP RIGHT/BOTTOM LEFT DOOR HINGE FOR 40385	31
79114	KETTLE SUPPORT PLATE FOR 40385	8	79126	METAL PIPE HOLDER FOR 40385	20	64178	TOP LEFT/BOTTOM RIGHT DOOR HINGE FOR 40385	31
79115	HANDLE FOR 40385	9	79127	SUPPORT PLATE FOR 40385	21	79138	FRONT DOOR RIGHT FOR 40385	32
79116	KETTLE LOCK FOR 40385	10	79128	BACK GLASS FOR 40385	22	64177	FRONT DOOR LEFT FOR 40385	32
79117	KETTLE LID FOR 40385	11	79129	LEFT-RIGHT GLASS FOR 40385	23	62448	COMPLETE KETTLE ASSEMBLY FOR 40385	

Trolley

Item No.	Description	Position	Item No.	Description	Position	Item No.	Description	Position
66218	SHORT TRIPOD OF TROLLEY FOR 40385	1	66223	HEXAGON SCREW OF TROLLEY FOR 40385	6	66229	LEFT SET FOR HANDLE OF TROLLEY FOR 40385	12
66219	BEARINGS OF TROLLEY FOR 40385	2	66225	LONG FEET OF TROLLEY FOR 40385	8	66230	CABINET OF TROLLEY FOR 40385	13
66220	WHEEL OF TROLLEY FOR 40385	3	66226	LONG BEAM OF TROLLEY FOR 40385	9	66231	COUNTERTOPS OF TROLLEY FOR 40385	14
66221	BUSHING OF TROLLEY FOR 40385	4	66227	RIGHT SET FOR HANDLE OF TROLLEY FOR 40385	10			
66222	FRONT COVER FOR WHEEL OF TROLLEY FOR 40385	5	66228	HANDLE OF TROLLEY FOR 40385	11			

Electrical Schematics

Model **CE-CN-0227-R** 40385

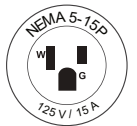
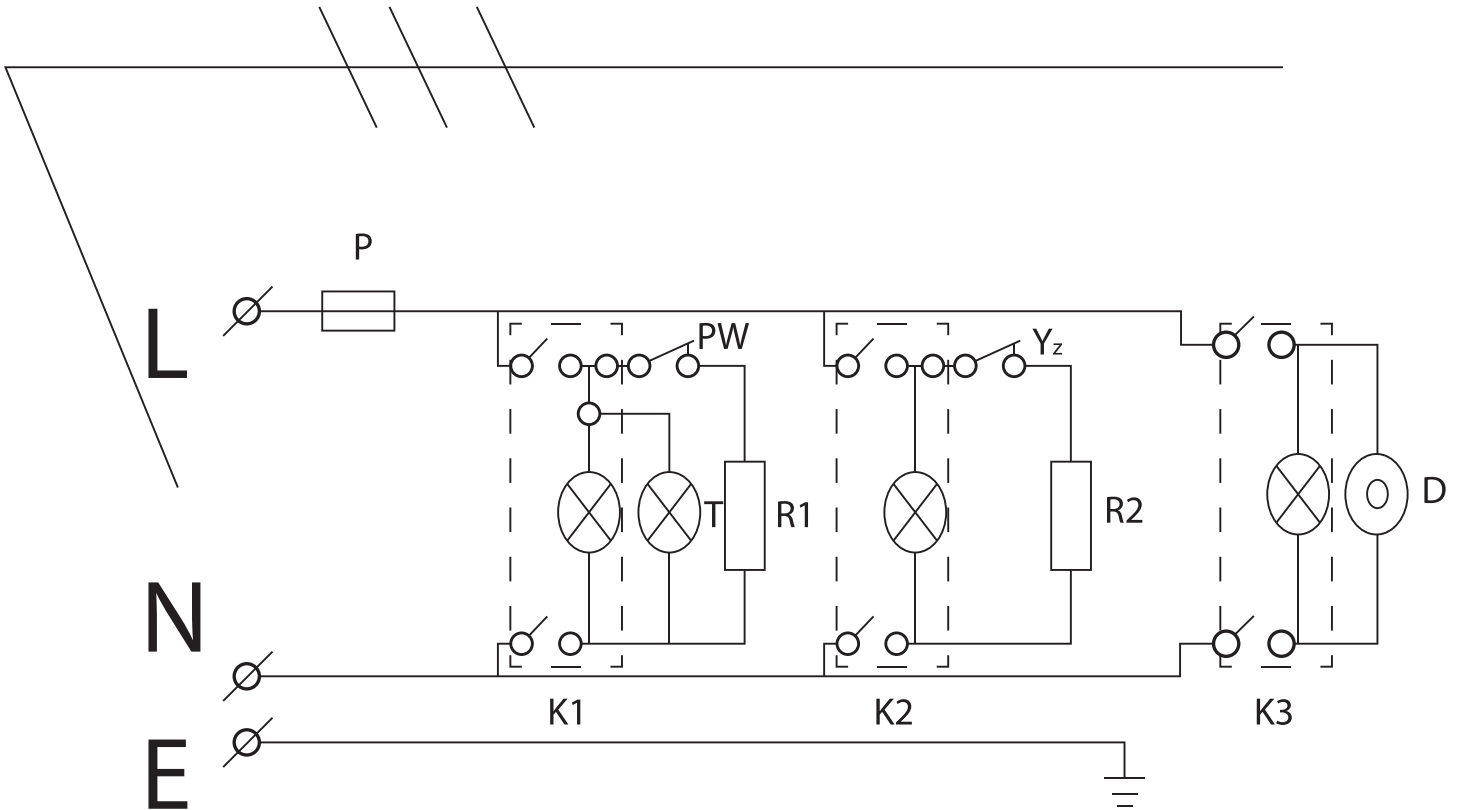



Warranty Registration

Thank you for purchasing an Omcan product. To register your warranty for this product, complete the information below, tear off the card at the perforation and then send to the address specified below. You can also register online by visiting:

Merci d'avoir acheté un produit Omcan. Pour enregistrer votre garantie pour ce produit, complétez les informations ci-dessous, détachez la carte au niveau de la perforation, puis l'envoyer à l'adresse spécifiée ci-dessous. Vous pouvez également vous inscrire en ligne en visitant:

Gracias por comprar un producto Omcan usted. Para registrar su garantía para este producto, complete la información a continuación, cortar la tarjeta en la perforación y luego enviarlo a la dirección indicada a continuación. También puede registrarse en línea en:

<https://omcan.com/warranty-registration/>

For mailing in Canada

Pour postale au Canada

Por correo en Canadá

For mailing in the US

Pour diffusion aux États-Unis

Por correo en los EE.UU.

OMCAN

PRODUCT WARRANTY REGISTRATION

3115 Pepper Mill Court,
Mississauga, Ontario
Canada, L5L 4X5

OMCAN

PRODUCT WARRANTY REGISTRATION

4450 Witmer Industrial Estates, Unit 4,
Niagara Falls, New York
USA, 14305

or email to: service@omcan.com



Purchaser's Information

Name: _____

Address: _____

City: _____ Province or State: _____ Postal or Zip: _____

Country: _____

Dealer from which Purchased: _____

Dealer City: _____ Dealer Province or State: _____

Invoice: _____

Model Name: _____ Model Number: _____

Machine Description: _____

Date of Purchase (MM/DD/YYYY): _____

Would you like to extend the warranty? Yes No

Company Name: _____

Telephone: _____

Email Address: _____

Type of Company:

Restaurant Bakery Deli

Butcher Supermarket Caterer

Institution (*specify*): _____

Other (*specify*): _____

Serial Number: _____

Date of Installation (MM/DD/YYYY): _____

Thank you for choosing Omcan | Merci d'avoir choisi Omcan | Gracias por elegir Omcan



Since 1951 Omcan has grown to become a leading distributor of equipment and supplies to the North American food service industry. Our success over these many years can be attributed to our commitment to strengthen and develop new and existing relationships with our valued customers and manufacturers. Today with partners in North America, Europe, Asia and South America, we continually work to improve and grow the company. We strive to offer customers exceptional value through our qualified local sales and service representatives who provide convenient access to over 6,500 globally sourced products.

Depuis 1951 Omcan a grandi pour devenir un des "leaders" de la distribution des équipements et matériel pour l'industrie des services alimentaires en Amérique du Nord. Notre succès au cours de ces nombreuses années peut être attribué à notre engagement à renforcer et à développer de nouvelles et existantes relations avec nos clients et les fabricants de valeur. Aujourd'hui avec des partenaires en Amérique du Nord, Europe, Asie et Amérique du Sud, nous travaillons continuellement à améliorer et développer l'entreprise. Nous nous efforçons d'offrir à nos clients une valeur exceptionnelle grâce à nos ventes locales qualifiées et des représentants de service qui offrent un accès facile à plus de 6500 produits provenant du monde entier.

Desde 1951 Omcan ha crecido hasta convertirse en un líder en la distribución de equipos y suministros de alimentos en América del Norte industria de servicios. Nuestro éxito en estos años se puede atribuir a nuestro compromiso de fortalecer y desarrollar nuevas relaciones existentes con nuestros valiosos clientes y fabricantes. Hoy con socios de América del Norte, Europa, Asia y América del Sur, que trabajan continuamente para mejorar y crecer la empresa. Nos esforzamos por ofrecer a nuestros clientes valor excepcional a través de nuestro local de ventas y representantes de los servicios que proporcionan un fácil acceso a más de 6,500 productos con origen a nivel mundial.

